



**PRODUCT
INSTRUCTION MANUAL**

Model Numbers: 909YWT/1109YWT

CAUTION:

**BEFORE USE, PLEASE READ AND FOLLOW ALL SAFETY RULES AND
OPERATING INSTRUCTIONS.**

**Avanti Products, A Division of The Mackle Co., Inc.
P.O. Box 520604 - Miami, Florida 33152
www.avantiproductions.com**

WARRANTY INFORMATION

Thank you for purchasing this fine Avanti product. Please fill out this card and return it within 100 days of purchase and receive these important benefits:

- **Confirm your warranty:**
Your prompt product registration confirms your right to the protection available under the terms and conditions of your Avanti warranty.
- **Protect your product:**
We will keep the model number and date of purchase of your new Avanti product on file to help you refer to this information in the event of an insurance claim such as fire or theft.
- **Promote better products:**
We value your input. Your responses will help us develop products designed to best meet your future needs.

------(detach here)-----

Avanti Registration Card

Name _____

Address _____

City _____ State _____ Zip _____

Area Code _____ Phone Number _____ Area _____

Code _____ Phone Number _____

Did You Purchase An Additional Warranty:

Extended Food Loss None

Reason For Choosing This Avanti Product:

Please indicate the most important factors that influenced your decision to purchase this product.

- Price
- Product Features
- Avanti Reputation
- Product Quality
- Salesperson Recommendation
- Friend/Relative Recommendation
- Warranty
- Other _____

Model # _____ Serial # _____

Date Purchased _____ Store/Dealer Name _____

Occupation _____

As Your Primary Residence, Do You:

Own Rent

Your Age:

Under 18 18-25 26-30
 31-35 36-50 over 50

Marital Status:

Married Single

Is This Product Used In The:

Home Business

How Did You Learn About This Product:

Advertising Product Features
 In Store Demo Personal Demo
 Other _____
Comments _____

HELP US HELP YOU...

Read this guide carefully.

It is intended to help you operate and maintain your new appliance properly.

Keep it handy to answer your questions.

If you don't understand something or your need more help, please call:

**Avanti Customer Service
800-220-5570**

Keep proof of original purchase date (such as your sales slip) with this guide to establish the warranty period.

CAUTION:

**THIS APPLIANCE IS NOT
DESIGNED FOR THE
STORAGE OF MEDICINE OR
OTHER MEDICAL PRODUCTS.**

Write down the model and serial numbers.

You'll find them on a plate located on the inside left wall the appliance.

Please write these numbers here:

Date of Purchase

Model Number

Serial Number

Use these numbers in any correspondence or service calls concerning your appliance.

If you received a damaged appliance, immediately contact the dealer (or builder) that sold you the appliance.

Save time and money. Before you call for service, check the Troubleshooting Guide. It lists causes of minor operating problems that you can correct yourself.

IF YOU NEED SERVICE

We're proud of our service and want you to be pleased. If for some reason you are not happy with the service you receive, here are some steps to follow for further help.

FIRST, contact the people who serviced your appliance. Explain why you are not pleased. In most cases, this will solve the problem.

NEXT, if you are still not pleased, write all the details, including your telephone number, and send to:

**Customer Service
Avanti Products
10880 NW 30 Street
Miami, FL 33172**

PARTS AND FEATURES

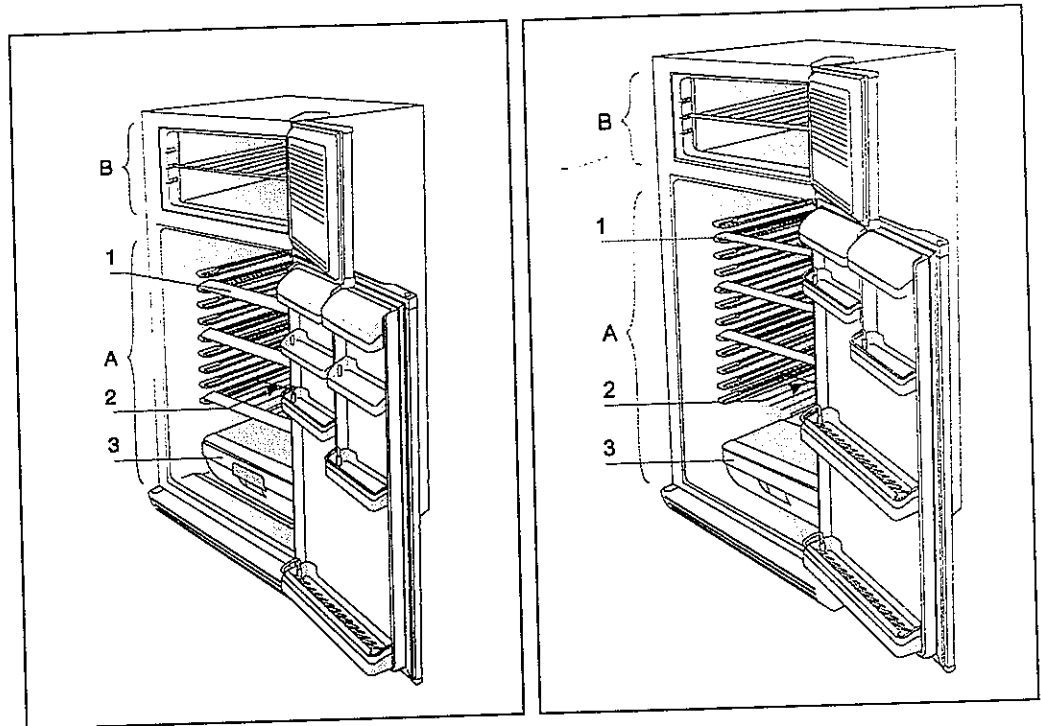

Refrigerator (A)

Refrigerator is used for storing fresh foods for few days.

Freezer (B)

Freezer is used for freezing fresh foods and for storing already frozen foods.

Shelf (1)

(Number of shelves depends on the model) Shelf can be optionally placed on the guides inside the appliance. This protects against pulling out. If you want to remove it, slightly lift up the back part and pull it out. Quickly perishable food should be stored in the back, which is the coldest part of the shelves.

Defrost Outlet (2)

The interior of the refrigerator is cooled with cooling plate incorporated in the rear wall. Under the plate there is a channel and an outlet for defrost water. Regularly check the defrost water outlet and the channel, because they should never be clogged (as for example with food crumbs). If clogged, use a plastic straw and clean it.

Fruit and Vegetable Container (3)

The container is on the bottom under the glass shelf and is used mainly for storing fruits and vegetables. It provides adequate humidity that has favorable effect on food stored (less dehydration).

Table of Contents

Warranty Information _____	2
Help Us Help You _____	3
Parts and features _____	4
Important Safety Instructions _____	6
Installation Instructions _____	6
Before Using Your Appliance _____	6
Installation of Your Appliance _____	7
Electrical Connection _____	8
Reversing the Door Swing of Your Appliance _____	10
Operating Your Appliance _____	10
Temperature Control _____	10
Freezing Fresh Foods _____	11
Freezing Procedure _____	11
Defrosting Your Appliance _____	11
Using Your Ice Cube Trays _____	12
Care and Maintenance _____	12
Cleaning Your Appliance _____	13
Maintenance of Your Appliance _____	13
Vacation Time _____	13
Moving Your Appliance _____	13
Energy Saving Tips _____	15
Troubleshooting Guide _____	16
Service For Your Appliance _____	16
Your Avanti Products Warranty _____	17

IMPORTANT SAFETY INSTRUCTIONS

⚡ WARNING ⚡	To reduce the risk of fire, electrical shock, or injury when using your appliance, follow these basic precautions:
<ul style="list-style-type: none">• Read all instructions before using the appliance.• DANGER or WARNING: Risk of child entrapment.• Child entrapment and suffocation are not problems of the past. Junked or abandoned appliances are still dangerous. . . even if they will "just sit in the garage a few days."• Before you throw away your old refrigerator or freezer: Take off the doors. Leave the shelves in place so that children may not easily climb inside.• Never allow children to operate, play with, or crawl inside the appliance.• Never clean appliance parts with flammable fluids. The fumes can create a fire hazard or explosion.• Do not store or use gasoline or any other flammable vapors and liquids in the vicinity of this or any other appliance. The fumes can create a fire hazard or explosion.	
-Save these instructions-	

INSTALLATION INSTRUCTIONS

➤ Before Using Your Appliance

- Remove the exterior and interior packing.
- Check to be sure you have all of the following parts:
 - Two Spacers
 - 2 Ice Cube Trays (model 1109YWT)
 - 1 Ice Cube Tray (model 909YWT)
 - Plastic Scraper
 - Glass Crisper Cover
 - Instruction Manual
- Before connecting the appliance to the power source, let it stand upright for approximately 2 hours. This will reduce the possibility of a malfunction in the cooling system from handling during transportation.
- Clean the interior surface with lukewarm water using a soft cloth.
- In case the interior accessories are not correctly placed, rearrange them as described in chapter "Parts and Features".

➤ Installation of Your Appliance

- Place your appliance on a floor that is strong enough to support the appliance when it is fully loaded. To level your appliance, adjust the legs at the front of the appliance (Fig 1).
- Two spacers attached to the appliance must be fitted onto the upper edge of the condenser, thus preventing the appliance from being installed too close to the wall. Spacers are manufactured for all-purpose function depending on the

distance of the condenser from the wall. Therefore turn spacers correspondingly and fix them to the appliance (Fig.2).

- Locate the appliance away from direct sunlight and sources of heat (stove, heater, radiator, etc.). Direct sunlight may affect the acrylic coating and heat sources may increase electrical consumption. Extreme cold ambient temperatures may also cause the appliance not to perform properly.
- Avoid locating the appliance in moist areas. Too much moisture in the air will cause frost to form quickly on the evaporator requiring more frequent defrosting of the appliance.

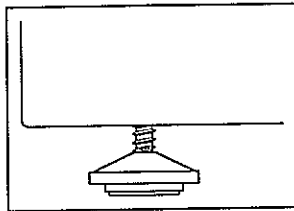

Fig. 1

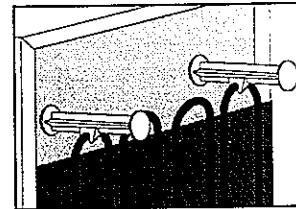

Fig. 2

➤ **Electrical Connection**

⚡ Warning ⚡

Improper use of the grounded plug can result in the risk of electrical shock. If the power cord is damaged, have it replaced by an authorized Avanti Products service center.

This appliance should be properly grounded for your safety. The power cord of this appliance is equipped with a three-prong plug which mates with standard three prong wall outlets to minimize the possibility of electrical shock.

Do not under any circumstances cut or remove the third ground prong from the power cord supplied.

Plug the appliance into an exclusive properly installed-grounded wall outlet. Do not under any circumstances cut or remove the third (ground) prong from the power cord. Any questions concerning power and or grounding should be directed toward a certified electrician or an authorized Avanti Products service center.

➤ **Use of extension cords is not recommended.**

This appliance requires a standard 115/120 volt, 60Hz electrical outlet with three-prong ground.

The cord should be secured behind the appliance and not left exposed or dangling to prevent accidental injury.

REVERSING THE DOOR SWING OF YOUR APPLIANCE

This appliance has the capability of either opening the door from the left or right side. The unit is delivered to you with the door opening from the left side. Should you desire to reverse the opening direction, please follow these instructions (refer to drawing on the following page).

NOTE:

All parts removed must be saved to do the reinstallation of the door.

- Remove the hinge cover on the right top of the cabinet.
- Remove the three bolts and washers (using a ratchet tool with a 8MM socket) that holds the top hinge to the cabinet. Keep these for later use.
- Lift the top hinge straight up to free the pin from the socket on the top of the door.
- Lift the freezer door and place it on a padded surface to prevent scratching it.
- Remove the plug buttons from the upper left holes as illustrated and transfer them to the uncovered holes at the right side. Be sure to press the plug buttons firmly into the holes.
- Unscrew the middle hinge and washer. Keep these for later use.
- Take off the refrigerator door and place it on a padded surface to prevent scratching.
- Release the kick plate by removing the two screws holding it.
- Lay the appliance on its back on the floor. Remove, change and replace the bottom hinge and plugs to the opposite side.
- Stand the unit upright and replace the refrigerator door.
- Insert the bottom of the middle hinge into the top of the refrigerator door. With the door open, screw the middle hinge into the uncovered holes. Do not tighten screw until you have checked the door is level.
- Place the bottom of the freezer door into the top of the middle hinge.
- Replace the top hinge in the uncovered holes on the top left side of the freezer. Do not tighten it until you have checked the door is level.
- Replace the hinge cover.
- Replace the lower kick plate, using the two screws previously removed.

CHANGING THE REVERSIBLE DOOR

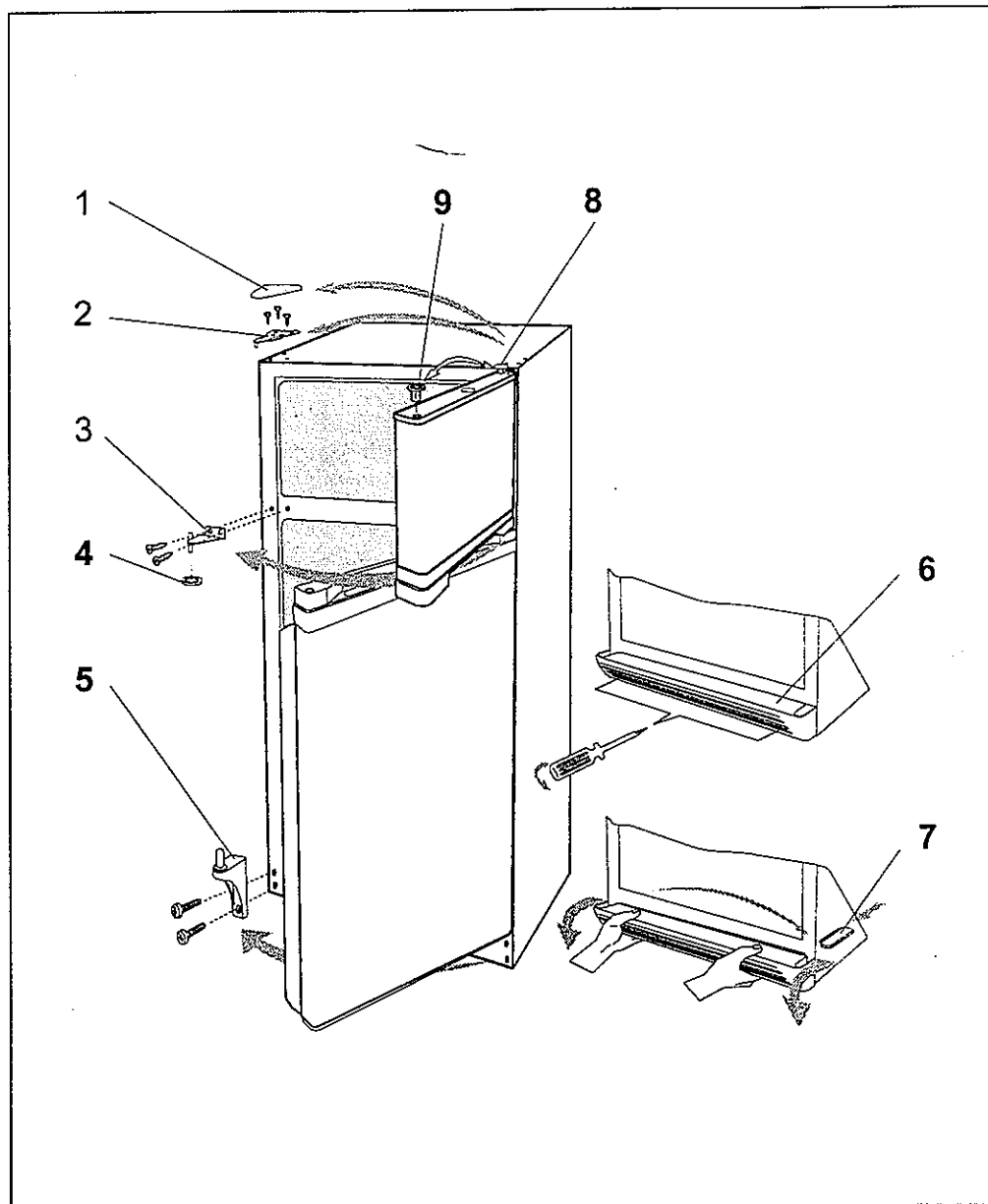

1. Upper Hinge Cover
2. Upper Hinge
3. Middle Hinge
4. Middle Hinge Washer
5. Lower Hinge

6. Kick Plate
7. Cover Plate of the Lower Hinge.
8. Door Hinge Plug
9. Door Hinge Fixture

OPERATING YOUR APPLIANCE

➤ Temperature Control

- Your appliance has only one control for regulating the temperature in the fresh food and the freezer compartment. The temperature control is located on the upper right hand side of the fresh food section.
- Higher settings on the knob (towards 7) mean lower temperatures (colder) in all compartments of the appliance. Temperature is normal, we recommend medium setting (4).
- The first time you turn the unit on set the temperature control to "4" or the mid-position.
- The range of the temperature control is from position "0" the warmest to "7" the coldest. After 24 to 48 hours, adjust the temperature control to the setting that best suits your needs. The setting of "4" should be correct for home or office appliance use.
- Changes of the ambient temperature affect temperature in the interior of the appliance (choose correct setting of the thermostat knob).
- To turn the appliance off, turn the temperature control to "0".

NOTE:

- Turning the temperature control to "0" position stops the cooling cycle but does not shut off the power to the appliance.
- If the unit is unplugged, power lost, or turned off; you must wait 3 to 5 minutes before restarting the unit. If you attempt to restart before this time delay, the appliance will not start.

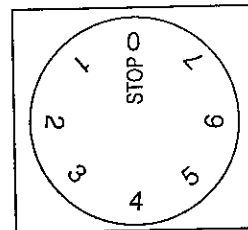

➤ Freezing Fresh Foods

- Proper use of the appliance, adequately packed food, correct temperature and taking into account hygienic precautions will substantially influence the quality of freezing the food or storing of the frozen foodstuffs.
- Carefully select food you intend to freeze; it should be of adequate quality and suitable for freezing.
- Use correct packaging and wrap it right.
 - The packaging should be air tight and shouldn't leak since this could cause substantial vitamin loss and dehydration of foods.
 - Foils and bags should be soft enough to tightly wrap around the foods.
- When preparing foods to be frozen, consider Sanitary precautions.
- Mark packages with following data: kind and amount of foods and the date of loading.
- **It is most important that the food is frozen as quickly as possible.**
- The amount of fresh foods that can be loaded in the freezer within 24 hours is indicated on the rating plate (freezing capacity). If the loading amount is too large, the quality of freezing is reduced which affects the quality of frozen foods.

➤ **Freezing Procedure**

- 24 hours before loading the freezer with fresh foods to be frozen, set the thermostat to position 4-7. Put packages on the shelf and let them freeze.
- 24 hours after loading the packages of fresh foods, reset the thermostat, if necessary, to operating temperature (See Temperature Selection) and reload the frozen packages to the bottom shelf.
- The next time you want to freeze fresh foods, repeat the freezing procedure and be careful that packages with fresh foods do not touch frozen packages.
- For freezing smaller amount of foods (up to 2 lbs) there is no need to change the thermostat setting (see Temperature Selection).

➤ **Defrosting Your Appliance**

- **When?** For the most efficient operation and minimum energy consumption, defrost the freezer compartment when the frost on the appliance walls is excessive or ¼ inch thick.

There is no need to defrost the refrigerator, because ice depositing on the inner back wall is defrosted automatically. Ice is depositing on the inner back wall during the compressor operation; later on, when the compressor is not operating ice is defrosting and water drops collect and drain through the outlet in the inner back wall into the drain pan situated above the compressor, from where it evaporates.

- **How?**

CAUTION

Do not use boiling water because it may damage the plastic parts. In addition, never use a sharp or metallic instrument to remove frost as it may damage the cooling coils and will void the warranty. We recommend using the plastic scraper.

- A few hours before defrosting set the thermostat to position 7, so foods are well frozen.
- Reset the thermostat to STOP (0) position and disconnect the power supply.
- Remove the frozen food from the appliance and place it in a cooler to protect the food.
- Leave the door open for a while so that you can easy scrape off the frost.
- Use a plastic scraper but be careful not to damage the inner surfaces of the freezer.
- Wipe up the scraped frost and ice before it is completely defrosted.

➤ **Using Your Ice Cube Trays**

- Recommended thermostat setting for ice making is between position 4 and 7.
- Fill the ice cube tray (two thirds of it) with cold water or with any liquid suitable for freezing and place the tray on the bottom of the freezer to freeze properly.
- Dry the tray, otherwise it may stick to the

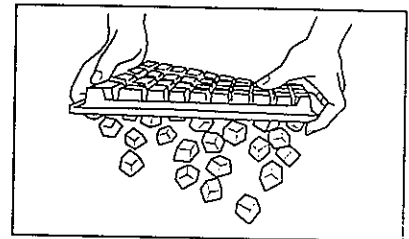

bottom of the freezer.

- The best method to get ice cubes out of the tray is to hold the tray under cold tap water for a second.
- To eject the ice cubes from the trays, place over the ice bucket and twist slightly.

CARE AND MAINTENANCE

➤ Cleaning Your Appliance

- Turn the temperature control to "0", unplug the appliance, and remove the food, shelves, and trays.
- Wash the inside with warm water and baking soda solution. The solution should be about 2 tablespoons of baking soda to a quart of water.
- Wash the shelves and trays with a mild detergent solution. Plastic parts cannot be washed in a washing machine.
- The outside of the appliance should be cleaned with mild detergent and warm water.
- The condenser coils should be vacuumed when they are dusty or dirty.
- Clean the drain pan on the refrigerator compressor. Do not remove the drain pan.
- After cleaning, connect the appliance to power supply and reload the packages.

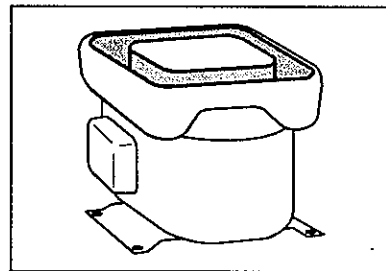
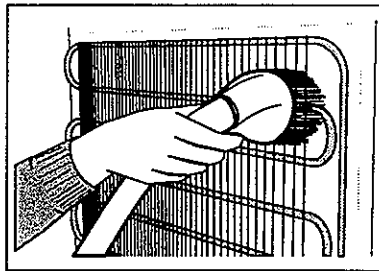

MAINTENANCE OF YOUR APPLIANCE

➤ Changing the Light Bulb

- Before replacing the light bulb, disconnect the appliance from the power supply.
- Press the cover at the rear side (in the arrow 1 direction) and remove the plastic cover (in the arrow 2 direction).
- Replace the bulb with a new one (size E14, max 10 Watt). Replace cover.
- Plug in the appliance.

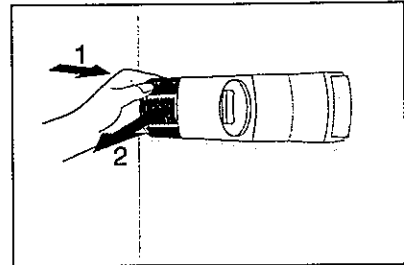

➤ Power Failure

Most power failures are corrected within a few hours and should not affect the temperature of your appliance if you minimize the number of times the door is opened. If the power is going to be off for a longer period of time, you need to take the proper steps to protect your food.

➤ Vacation Time

During long absences, remove all the food; unplug your appliance, clean your appliance, and leave the door slightly open to avoid possible formation of condensation, mold, or odors.

➤ Moving Your Appliance

- Remove all the food.
- Securely tape down all loose items inside your appliance.
- Turn the leveling screws up to the base to avoid damage.
- Tape the doors shut.
- Be sure the appliance stays in the upright position during transportation.

➤ Energy Saving Tips

- The appliance should be located in the coolest area of the room, away from heat producing appliances or heating ducts, and out of the direct sunlight.
- Let hot foods cool to room temperature before placing in the appliance. Overloading the appliance forces the compressor to run longer. Foods that freeze too slowly may lose quality, or spoil.
- Be sure to wrap foods properly, and wipe containers dry before placing them in the appliance. This cuts down on frost build-up inside the appliance.
- Appliance storage bin should not be lined with aluminum foil, wax paper, or paper toweling. Liners interfere with cold air circulation, making the appliance less efficient.
- Organize and label food to reduce door openings and extended searches. Remove as many items as needed at one time, and close the door as soon as possible.
- Try not to open the door too often, especially when the weather is wet and hot.

- Every so often check if the appliance is sufficiently ventilated.
- Ice and frost layer increase energy consumption, so clean the appliance as soon as the layer is $\frac{1}{4}$ " thick.

TROUBLESHOOTING GUIDE

PROBLEMS WITH YOUR APPLIANCE?

You can solve many common appliance problems easily, saving you the cost of a possible service call. Try the suggestions below to see if you can solve the problem before calling the servicer.

PROBLEM	POSSIBLE CAUSE
Appliance does not operate.	Not plugged in. The circuit breaker tripped or blown fuse. The appliance temperature control is set at "0".
Compressor turns on and off frequently.	Condenser coil at the back of the unit is dirty. The room temperature is hotter than normal. A large amount of food has been added to the appliance. The door is open too often. The door is not closed completely. The temperature control is not set correctly. The door gasket does not seal properly. The appliance does not have the correct clearances.
The light does not work.	The home circuit breaker or fuse has tripped. The appliance is unplugged. The bulb has burned out (see the maintenance section for the replacement procedure).
Vibrations.	Check to assure that the appliance is level.
The appliance seems to make too much noise.	The rattling noise may come from the flow of the refrigerant, which is normal. As each cycle ends, you may hear gurgling sounds caused by the flow of refrigerant in your appliance. Contraction and expansion of the inside walls may cause popping and crackling noises. The appliance is not level.
The door will not close properly.	The appliance is not level. The doors were reversed and not properly installed. The gasket is dirty. The shelves, bins, or baskets are out of position.

SERVICE FOR YOUR APPLIANCE

We are proud of our customer service organization and the network of professional service technicians that provide service on your Avanti appliances. With the purchase of your Avanti appliance, you can have the confidence that if you ever need additional information or assistance, the Avanti Products Customer Service team will be here for you. Just call us toll-free.

AVANTI PRODUCTS CUSTOMER SERVICES

Product Information 800-323-5029	Whatever your questions are about our products, help is available.
Part Orders 800-220-5570	You may order parts and accessories that will be delivered directly to your home. You may order these items by personal check, money order, Master Card, or Visa.
In-Home Repair Service 800-220-5570	An Avanti Products authorized service center will provide expert repair service, scheduled at a time that is convenient for you. Our trained servicers know your appliance inside and out.

YOUR Avanti Products WARRANTY

Staple your sales receipt here. Proof of original purchase date is needed to obtain service under warranty.

WHAT IS COVERED LIMITED ONE-YEAR WARRANTY

For one year from the date of purchase by the original owner, Avanti Products will, at its option, repair or replace any part of the appliance which proves to be defective in material or workmanship under normal use. During this period Avanti Products will provide all parts and labor necessary to correct such defects free of charge, so long as the appliance has been installed and operated in accordance with the written instructions in this manual. In rental or commercial use, the warranty period is 90 days. All Avanti appliances of 3.5 cubic foot capacity or less must be brought/sent to the applicable service shop for repair.

LIMITED SECOND THROUGH FIFTH YEAR WARRANTY

For the second through the fifth year from date of original purchase, Avanti Products will provide a replacement compressor free of charge due to a failure. You are responsible for the service labor and freight charges. In rental or commercial use, the limited compressor warranty is one year and nine months. Cost to move the appliance to the servicers' shop and back to the user's home, as may be required, are the user's responsibility.

WHAT IS NOT COVERED

- Content losses of food due to spoilage.
- Incidental or consequential damages.
- Parts and labor costs for the following will not be considered as warranty:
 - Evaporator doors, door springs, and/or frames.
 - Inner door panels, door shelves, door rails, and/or door supports.
 - Chest appliance lid liners.
 - Vegetable crispers.
 - Light bulbs and/or plastic housing.
 - Plastic cabinet liners.
 - Punctured evaporator that voids the warranty on the complete sealed system.
- Repairs performed by unauthorized servicers.
- Service calls that do not involve defects in material or workmanship such as customer education, door reversal, or proper installation.
- Service calls that are related to external problems, such as abuse, misuse, inadequate electrical power, accidents, fire, floods, or acts of God.
- Replacement of house fuses or resetting circuit breakers.
- Failure of the product if it is used for other than its intended purpose.
- This warranty does not outside the Continental USA.