

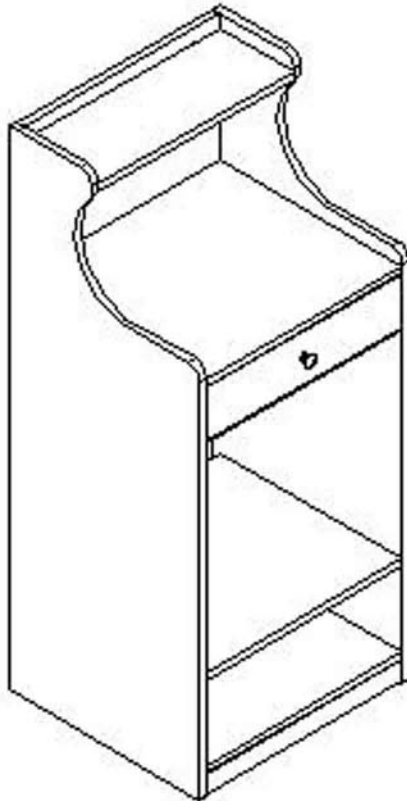

INSTALLATION MANUAL

Model Number: HC100 Hospitality Cabinet



CAUTION:

BEFORE USE, PLEASE READ AND FOLLOW ALL SAFETY RULES AND OPERATING INSTRUCTIONS.

Avanti has a policy of continuous improvement on its products and reserves the right to change materials and specifications without notice.

Avanti Products
P.O. Box 520604 - Miami, Florida 33152
www.avantiproducts.com

- Thank you for purchasing our product, carefully read and follow all assembly instructions before assembling this item.
- Please make sure that you have all the parts and hardware as indicated before beginning the assembly of this item.
- Use the hardware illustrations to determine correct piece and size.
- This item should be assembled on a soft surface to prevent scratching the finish during assembly.
- Do not tighten all the screws and/or anchors until you have a good fit.

This unit is supplied in an un-assembled state and must be assembled.

- a) The unit is very heavy and should not be carried by one person. To avoid injury to yourself and/or damage to the unit we recommend you carry the unit between 2 or more persons.

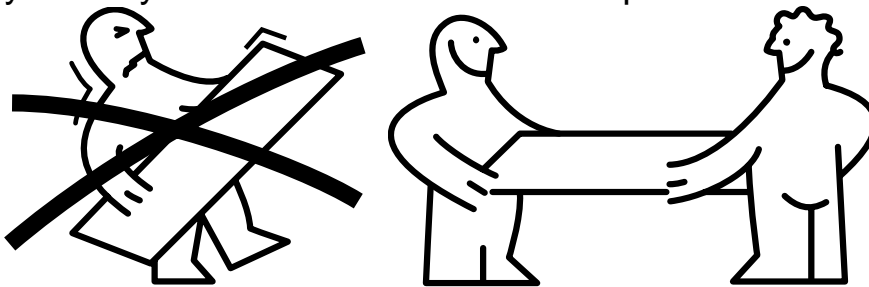

- b) Before assembly place all parts on a soft stable surface to avoid scratching or damaging the finish.

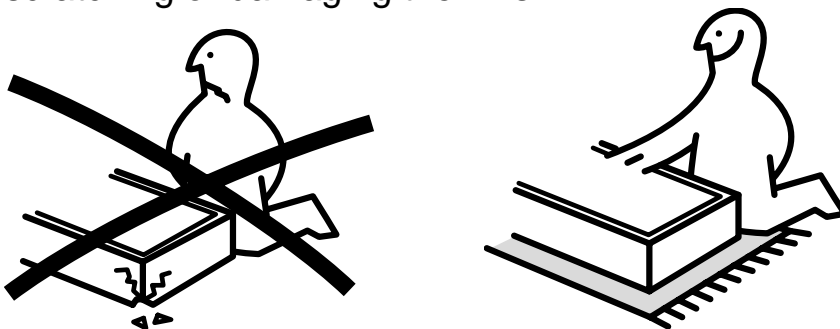

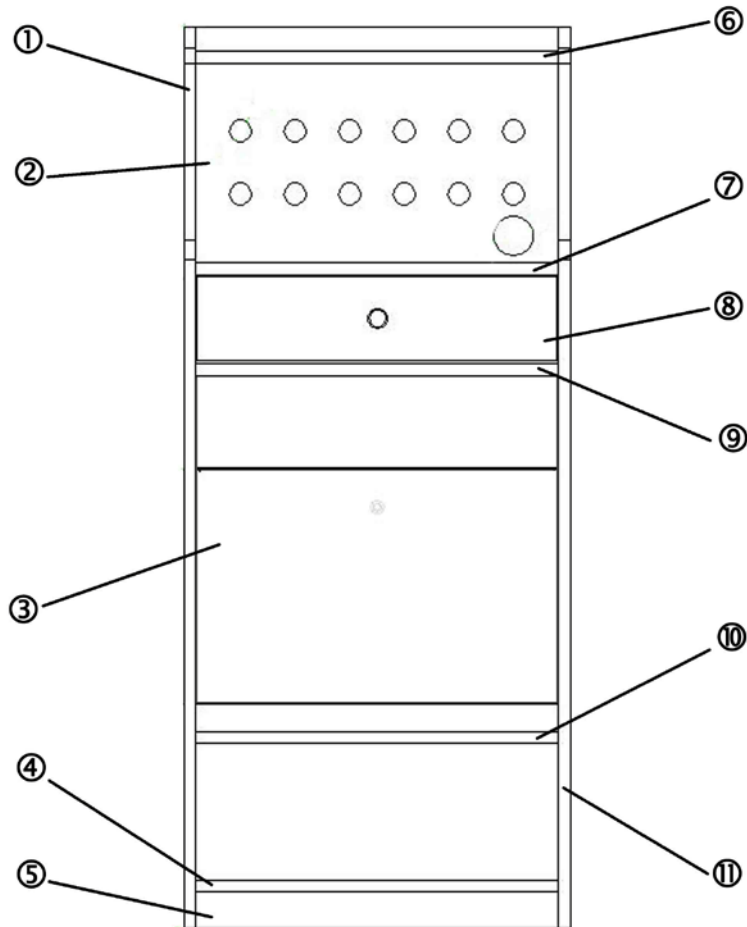

Parts:

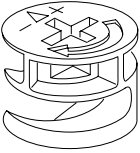
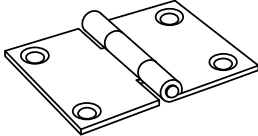

Part #	Part Description	Qty Included
1	Left Side Panel	1
2	Back Panel – Microwave Section	1
3	Back Panel – Refrigerator Section	1
4	Bottom Panel – Refrigerator Section	1
5	Front Fascia	1
6	Top Shelf Panel	1
7	Bottom Panel – Microwave Section	1
8	Door – Dry Storage Section	1
9	Bottom Panel – Dry Storage Section	1
10	Adjustable Shelf – Refrigerator Section	1
11	Right Side Panel	1

Assembly Hardware

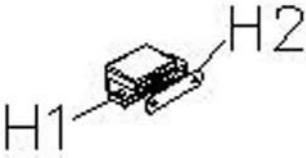
Part No.	Illustration / Description	Qty included
A	 <p data-bbox="456 656 815 696">Anchor Bolt and Lock</p>	22 Pieces
B	<p data-bbox="456 813 671 853">Wood Dowel</p>	32 Pieces
C	<p data-bbox="456 947 608 992">Shelf Pin</p>	4 Pieces
D	 <p data-bbox="456 1167 647 1205">Door Hinge</p>	2 Pieces
E	<p data-bbox="456 1323 791 1361">ST3.5 X 15 – Screw</p>	12 Pieces
F	 <p data-bbox="456 1552 730 1592">Door Pull - Knob</p>	1 Piece
G	<p data-bbox="456 1727 746 1765">ST4 x 20 - Screw</p>	1 Piece
H	 <p data-bbox="456 1962 810 1998">Magnetic Door Catch</p>	1 Piece

Tools required to assembly this unit:

Be sure that you have the following at hand prior to beginning the assembly:

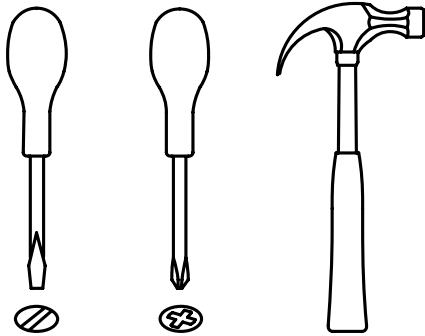

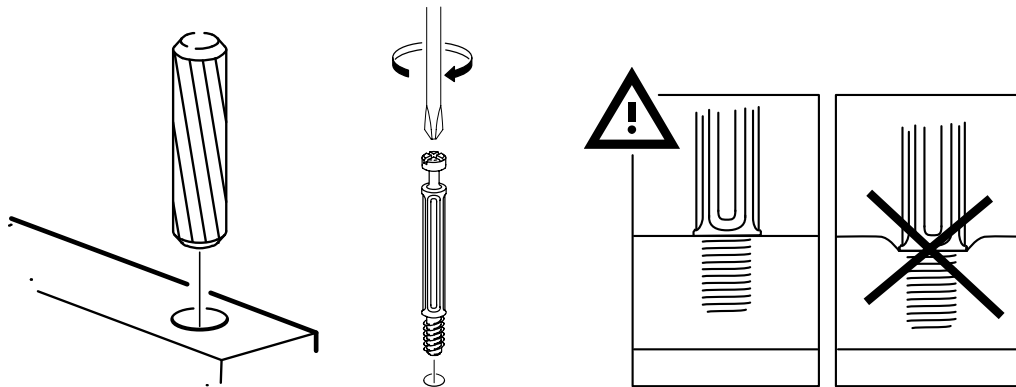

When installing the assembly hardware be sure that you insert all screws, anchor bolts, and dowels straight and are flush to the surface of the unit. Over tightening of the hardware will result in damage to the finish and a poor fit.



STEP 1:

As shown in the illustration (fig. 1) attach the (2) back panels (parts 2 & 3) to the left side panel.

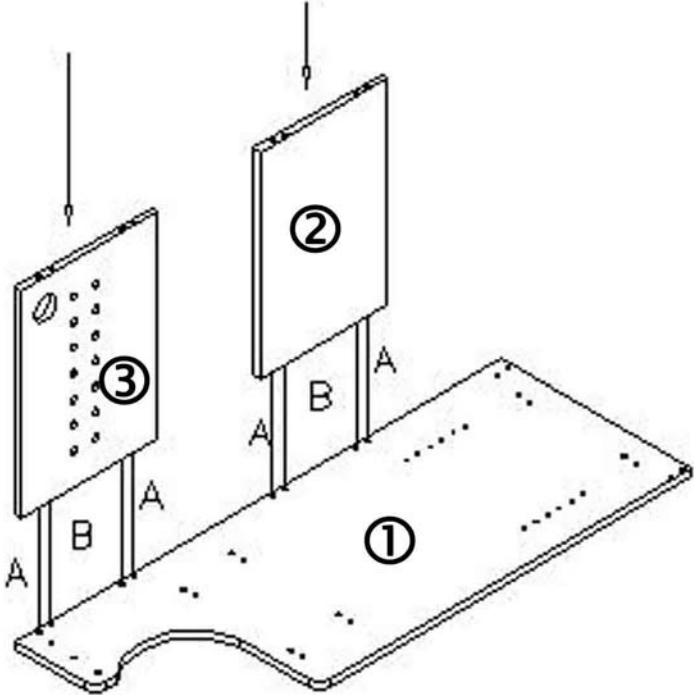
Part	Description
1	Left Side Panel
2	Back Panel – Microwave Section
3	Back Panel – Refrigerator Section

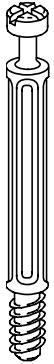
Fig. 1	Assembly Parts Used
	<p>Part A:</p>   <p>Part B:</p>

STEP 2:

As shown in the illustration (fig. 2) attach the (4) horizontal panels (parts 4, 5, 6, 7, and 9) to the left side panel. As well as attach the magnetic (H1) portion to the inside area of the storage compartment.

Part	Description
4	Bottom Panel – Refrigerator Section
5	Front Fascia
6	Top Shelf Panel
7	Bottom Panel – Microwave Section
9	Bottom Panel – Dry Storage Section

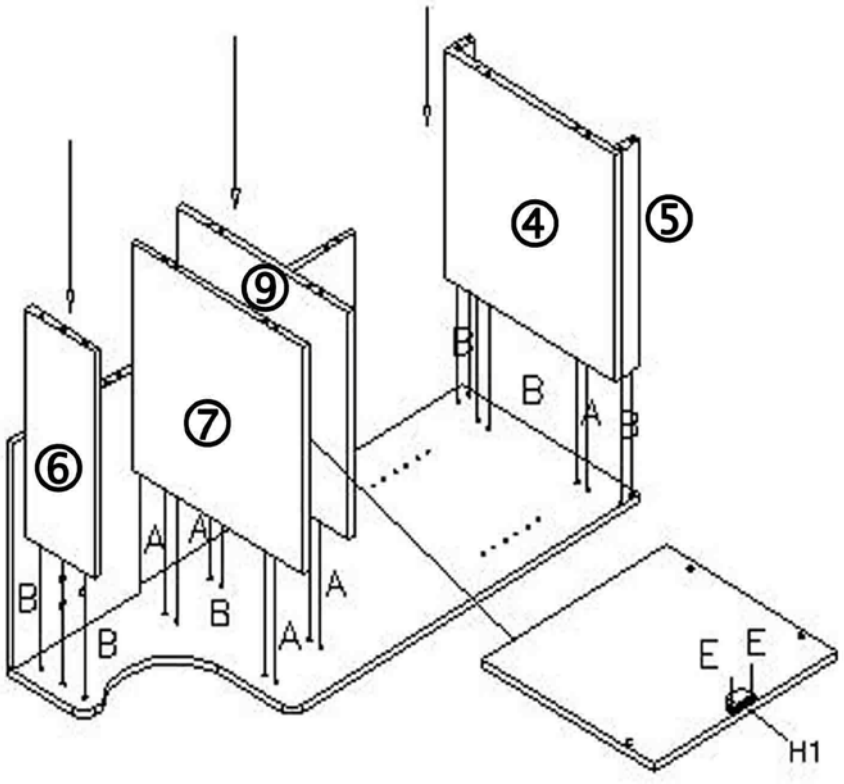
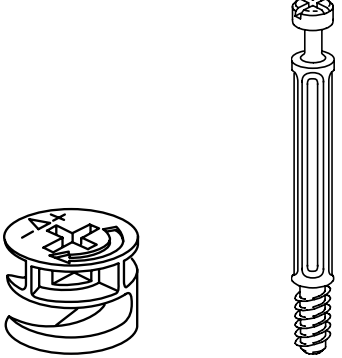
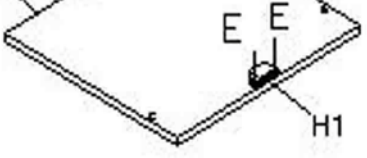
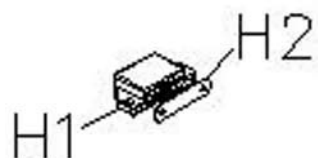
Fig. 2	Assembly Parts Used
	<p>Part A:</p> 
	<p>Part B:</p>
	<p>Part H: (H1)</p> 

STEP 3:

As shown in the illustration (fig. 3) attach the right side panel (part 11) to the panels installed in steps 1 and 2.

Part	Description
11	Right Side Panel

Fig. 3	Assembly Parts Used
	<p>Part A:</p>
	<p>Part B:</p>

STEP 4:

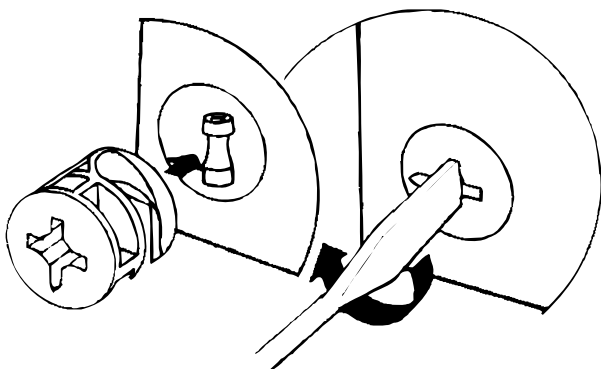

Once you have all of the wooden panels assembled and with a good fit, tighten securely all anchor locks.



STEP 5:

As shown in the illustration (fig. 5) install the front storage door (part 8) and place the refrigerator support shelf (part 10) in position. Install the metal catch (H2) portion of the magnetic door catch to the storage door as shown below:

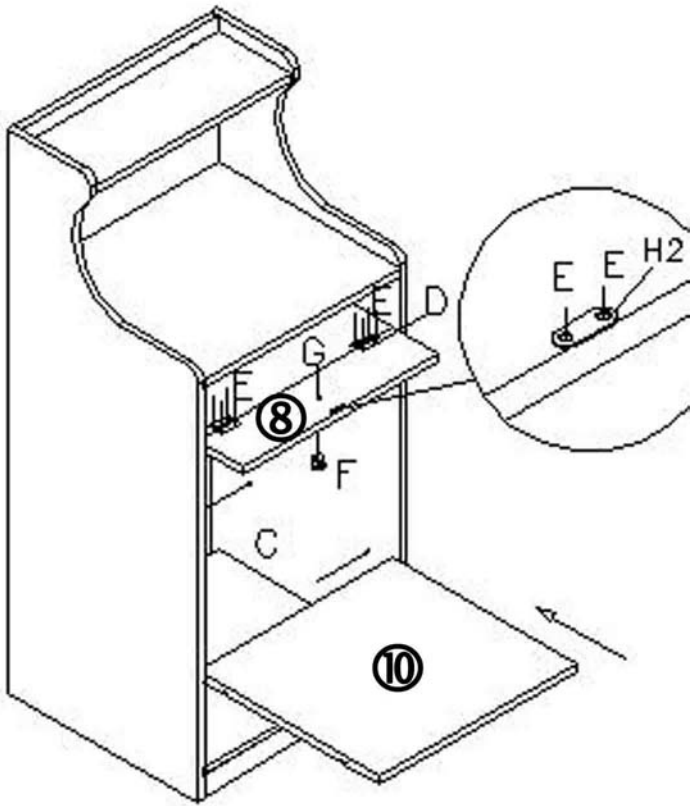
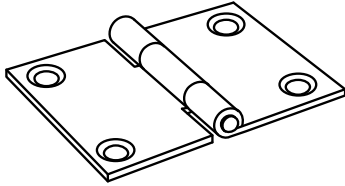
Part	Description
8	Door – Dry Storage Section
10	Adjustable Shelf – Refrigerator Section

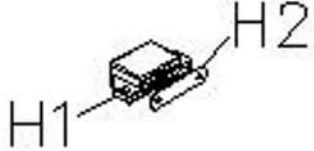
Fig. 5	Assembly Parts Used
	Part C:
	Part D: 
	Part E:
	Part F: 
	Part G:
Part H: (H2) 	

Registration Information

Thank you for purchasing this fine Avanti product. Please fill out this card and return it within 100 days of purchase and receive these important benefits:

- **Protect your product:**
We will keep the model number and date of purchase of your new Avanti product on file to help you refer to this information in the event of an insurance claim such as fire or theft.
- **Promote better products:**
We value your input. Your responses will help us develop products designed to best meet your future needs.

----- (detach here) -----

Avanti Registration Card

Name _____			Model # _____	Serial # _____
Address _____			Date Purchased _____	Store/Dealer Name _____
City _____	State _____	Zip _____	Occupation _____	
Area Code _____	Phone Number _____		<u>As Your Primary Residence, Do You:</u> <input type="checkbox"/> Own <input type="checkbox"/> Rent	
<u>Did You Purchase An Additional Warranty:</u> <input type="checkbox"/> Extended <input type="checkbox"/> None			<u>Your Age:</u> <input type="checkbox"/> under 18 <input type="checkbox"/> 18-25 <input type="checkbox"/> 26-30 <input type="checkbox"/> 31-35 <input type="checkbox"/> 36-50 <input type="checkbox"/> over 50	
<u>Reason For Choosing This Avanti Product:</u> Please indicate the most important factors that influenced your decision to purchase this product. <input type="checkbox"/> Price <input type="checkbox"/> Product Features <input type="checkbox"/> Avanti Reputation <input type="checkbox"/> Product Quality <input type="checkbox"/> Salesperson Recommendation <input type="checkbox"/> Friend/Relative Recommendation <input type="checkbox"/> Warranty <input type="checkbox"/> Other _____			<u>Marital Status:</u> <input type="checkbox"/> Married <input type="checkbox"/> Single <u>Is This Product Used In The:</u> <input type="checkbox"/> Home <input type="checkbox"/> Business <u>How Did You Learn About This Product:</u> <input type="checkbox"/> Advertising <input type="checkbox"/> Product Features <input type="checkbox"/> In Store Demo <input type="checkbox"/> Personal Demo <input type="checkbox"/> Other _____	
			Comments _____ _____ _____	





PRINTED IN CHINA