

TebaTM MINI KITCHEN

by **Avanti**

TFL-12

Instruction Manual

BEFORE USE, PLEASE READ AND FOLLOW ALL SAFETY RULES AND OPERATING INSTRUCTIONS.
Avanti has a policy of continuous improvement on its products and reserves the right to change materials and specifications without notice.

Avanti Products, A Division of The Mackle Co., Inc.
P.O. Box 520604 - Miami, Florida 33152
www.avantiproducts.com

IMPORTANT SAFETY INSTRUCTIONS

⚠ WARNING ⚠

To reduce the risk of fire, electrical shock, or injury when using your Mini-Kitchen, follow these precautions:

- Read all instructions before using this appliance.
- Never clean the appliance with flammable liquids. The fumes can create a fire hazard or explosion.
- Do not store or use gasoline or other flammable products in the vicinity of this appliance. The fumes can create a fire hazard or explosion.

SAFETY PRECAUTIONS

- Do not leave children alone or unattended where an oven is hot or in operation.
- Never use your appliance for heating the room. Your oven and cooktop are not designed to heat your kitchen. Top burners should not be operated without cookware.
- Never pick up a flaming pan. Turn the controls off.
- Smother a flaming pan on a surface unit by covering the pan completely with a well fitting lid.
- Do not use water on grease fires. Flaming grease outside a pan can be put out by covering it with baking soda, multipurpose dry chemical, or fire extinguisher. Flame in the oven can be smothered completely by closing the oven door and turning the oven off or by using baking soda, multipurpose dry chemical, or fire extinguisher.
- Do not store or use combustible materials in an oven or near the cooktop.
- Turn cookware handles toward the side or back of the oven without letting them extend over adjacent burners, to minimize the possibility of burns.
- Always heat fat slowly and watch as it heats.
- Never try to move a pan of hot fat, especially a deep fat fryer. Wait until the fat is cool.
- When using glass cookware, make sure it is designed for top-of-oven cooking.
- Use proper pan size. Avoid pans that are unstable or easily tipped. Select cookware having flat bottoms large enough to properly contain food and avoid boilovers and spillovers.
- The glass ceramic range top and the bottom of the pot must always be clean and dry. While cooking, remains of dirt and food as well as of cleansers may burn into the surface and damage it. Pointed and hard objects falling on the ceramic range top may also cause damage.
- Do not leave any items on the cooktop.
- Do not use the oven for a storage area. Items stored in the oven can ignite.
- Place the oven shelves in the desired position while the oven is cool.
- Do not heat unopened food containers. Pressure could build up and the container could burst, causing an injury.
- Do not use aluminum foil anywhere in the oven except as described in the manual. Misuse could result in a fire hazard or damage to the oven.
- Never entirely cover a shelf with aluminum foil. This will disturb the heat circulation and result in poor baking.
- When using cooking or roasting bags in the oven, follow the manufacturer instructions.
- To avoid scratching, marring, discoloration or fire hazard, do not store anything on top of the oven, especially during operation.
- The work surface must be heat resistant and dry.
- The oven sides may become very hot during use.
- Oversized foods, metal foil packages, or utensils must not be inserted in the oven as they may create a fire or risk of electric shock.

Your oven temperature is controlled very accurately using an oven control system. It is recommended that you operate the oven for a number of weeks to become familiar with your new oven's performance.

- To avoid possible burns, place the shelves in the correct position before you turn the oven on.
- Close the oven door. Turn the oven set knob to the temperature you desire.
- Check the food for doneness at the minimum time on the recipe. Cook longer if necessary. Remember to cut the cooking time on your recipe by 25% when using the convectional cooking.
- Turn the oven set knob to off and then remove the food.
- Stand away from the oven when opening the door of a hot oven. The hot air and steam that escape can cause burns to hands, face, and eyes.

Table of Contents

Important Safety Instructions	2
Part And Features	4
Control Panel	5
Covectional Cooking	6
Installation Instructions	6
Before Using Your Minikitchen	6
Using Your Minikitchen	7
Electrical Requirements Leveling Of Oven	7
Bake	7
Rotisserie Roasting	8
Broiling	9
Oven Burner	9
Ceramic Range Top	9
Keep Warm	9
Care And Maintenance	10
Cleaning Your Mini-Kitchen	10
Helpful Hints	10
Receipes	11-17
Problems With Your Appliance	18
Troubleshooting Guide	18
Service For You Minikitchen	19
Warranty Information	20
Help Us Help You	21
Your Avanti Products Warranty	22

Parts and Features

Temperature Control

Choose the desired or recommended temperature up to 450°.

Time Control

When you turn the knob to the right to the "M" manual position, the oven will remain on until it is manually shut off. To activate the timer, turn the knob to the desired position. The timer is used for Warm, Bake, Oven Burner, High Broil, Low Broil, and Rotisserie Cooking. When the time has elapsed or the knob is manually turned to the "0" position the oven will automatically shut off.

Function Control

Select desired cooking function (Bake, Oven Burner, High Broil, Low Broil, and Rotisserie Cooking.)

Oven Rack

Used in one of five positions during Warm, Bake, Oven Burner, High Broil, and Low Broil cooking.

Drip/Baking Pan

Slides into rails below the rack position in the oven during Warm, Bake, Oven Burner, High Broil, Low Broil, and Rotisserie Cooking.

Roasting Rack

Fits into the drip/baking pan for broiling and rotisserie.

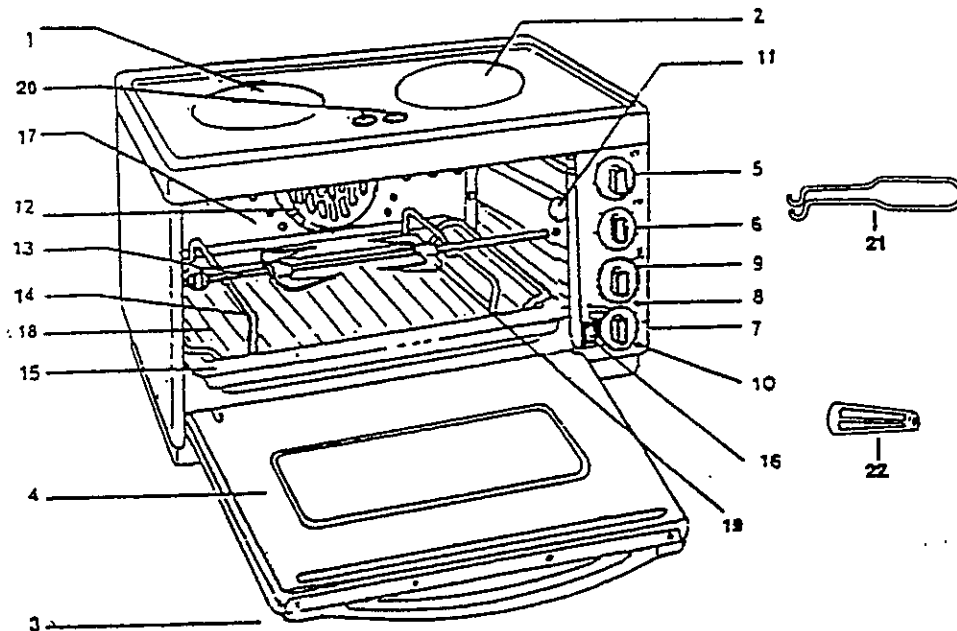

- | | |
|-------------------------------------|--------------------------------------|
| 1. 600w Ceramic Burner | 13. Skewer |
| 2. 1000w Ceramic Burner | 14. Rotary Skewer Holder |
| 3. Door Handle | 15. Enamelled Roasting/Broiling Pan |
| 4. Oven Door | 16. Convection Switch |
| 5. Left Burner Temperature Control | 17. Fan Motor Protector |
| 6. Right Burner Temperature Control | 18. Wire Rack |
| 7. Function Selector | 19. Meat Prongs |
| 8. Temperature Light | 20. Heat Indicator Lights |
| 9. Timer | 21. Metal Skewer Handling Tool |
| 10. Power Indicator Light | 22. Plastic Skewer Handle |
| 11. Skewer Hole Cover | 23. Metal Roasting Pan Handling Tool |
| 12. Convection Fan | |

Control Panel

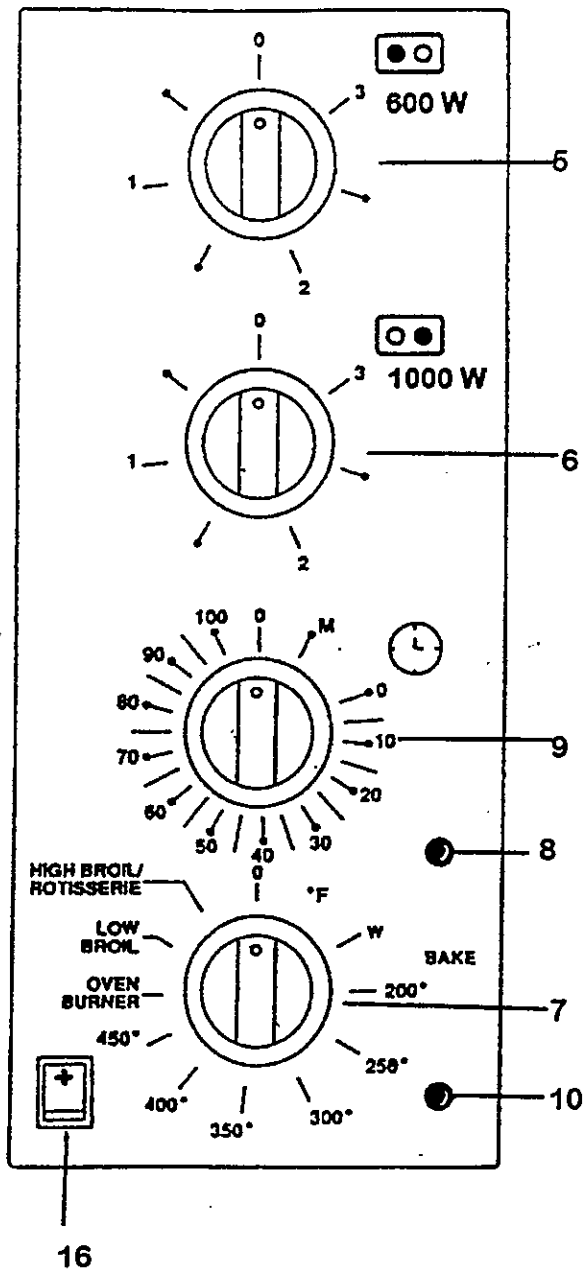

(9) Timer:

Turn the knob clockwise to choose desired time setting. There is a total operation time of 100 minutes.

When the timer is used the appliance will automatically turn off at the programmed time. The operation time may be readjusted at any time during operation by turning the timer control either clockwise or counterclockwise.

If the continuous operation manual "M" position is used, the appliance does not automatically switch off. In order to switch it off the timer control has to be turned back to "0".

(5 & 6) Temperature Control For Burners:

The controls for the burners are situated on the control panel beside the oven door. The top control operates the left burner, the bottom control operates the right burner. Each burner has a range of six temperature settings marked ½ (low) to 3 (high). To switch the burner off turn the control knob to the "0" setting. Each burner is operated by turning the control knob. At the same time the operation light will illuminate.

(8) Temperature Light:

This light will only come on when the timer is set and the oven functions are being used. It will stay on until the desired oven temperature setting is reached. Then will cycle on and off during use to maintain the preset temperature. This is normal.

(10) Power Indicator Light:

This light will come on when the range top or oven functions are in use. It will stay on when your appliance is in use.

(Operation will not begin until the timer is set during use of any of the oven functions.)

Off Position

To switch the oven off, turn the function selector to "0" position.

(7) Function Selector:

There are six functions, Warm, Bake, Oven Burner, Low Broil, High Broil, and Rotisserie.

(16) Convection Switch

Push the button to the on position and the convection fan will function. Convection cooking may be used in the , Warm, Bake, Oven Burner, Low Broil, High Broil and Rotisserie position.

Convectional cooking is the preferred method of cooking by professional chefs. Their exquisitely prepared meals are due in part to the unique features of their ovens- Convection Fans. You get superior results while saving time and energy.

Convection cooking is a system which forces heated air to circulate through the oven. The gently circulated air envelops the food requiring less turning and basting and resulting in a 25% reduction in cooking times and more uniform cooking.

Your Teba mini-kitchen can perform convection cooking during Bake, Oven Burner, High Broil, Low Broil, and Rotisserie Cooking.

When roasting meats, the fan circulates hot air around the roast sealing in flavor and juices. Roast is crispy and evenly browned on the outside, moist and flavorful on the inside.

When baking, the fan maintains uniform heat throughout the oven, just like the ovens professionals' use. Baked goods are even, golden brown like those from the finest pastry shops. Large, half-sheet pans slide right into the oven in the place of the rack.

What is the oven burner function? Your new Teba Mini-Kitchen is a complete cooking system. The unique enclosed lower heating element allows you to cook on the bottom of the oven without using any racks. Used during the final cooking stage, the bottom only heat can be used to complete the cooking of foods, which require a higher base temperature without scorching.



INSTALLATION INSTRUCTIONS

➤ **Before Using Your Mini-Kitchen**

- Remove the exterior and interior packing.
- Check to be sure you have all of the parts listed below:
 - 2 Oven Racks.
 - 1 Broiling Pan
 - 1 Rotisserie Rack
 - 1 Roasting Pan Handling Tool
 - 1 Metal Skewer
 - 1 Plastic Skewer Handle
 - Instruction Manual
- Remove all the items inside your oven and clean the interior surface with lukewarm water using a soft cloth. (See "Cleaning" on Page 10)
- Do not attempt to repair or replace any part of your oven unless it is specifically recommended in this manual.
- Place your oven on a level surface such as a countertop or table. Be sure the sides, back, and tip of the oven are at least 1 inch away from any walls, cabinets, or objects on the counter or table.
- This appliance requires 1600 watts and should be the only appliance operating on the circuit.

NOTICE

Before you use this oven for the first time: The heating elements have a protective coating, which must be burned off before use. To do this, open the oven door and set the temperature to 450° F. Leave the appliance switched on for approximately 15 minutes. It is important to ensure adequate ventilation during period.

The burners also have a protective coating, which must be burned off before use. To do this, set the controls to the maximum setting 5 minutes. It is important to ensure the room is well ventilated during this period. Switch off the burners and allow cooling completely.

➤ **Using Your Mini-Kitchen**

Be sure to familiarize yourself with the oven functions and accessories prior to the first use.

- Be sure that the temperature control is set on "0" and the Time control is set to "Off" before plugging the cord into the outlet for use and when unplugging the oven after use.
- Open oven door to confirm nothing is stored in the oven cavity and set racks to proper height.
- Turn the oven knob to the desired temperature.
- When selected temperature is reached, the burner will maintain it. However, the light will cycle off and on.
- Do not forget that because heat rises, the top of oven will always be hotter than the bottom.
- After cooking time elapses, turn oven knob to OFF position and remove food.

➤ **Electrical Connections**

- This appliance requires a standard 115/120 volts, 60 Hz electrical outlet.
- The cord should be secured behind the appliance and not left exposed or dangling to prevent accidental injury.
- Do not pinch, knot, or bend the power cord in any manner.
- To protect against electrical shock, do not immerse cord, plug, or appliance itself in water or other liquid.
- Use of extension cord is not recommended.
- Never unplug the oven by pulling the power cord. Always grip the plug firmly and pull straight out from the receptacle.
- If the power cord is damaged, have it replaced by an authorized Avanti Products Service Center.

➤ **Bake**

The top and bottom heating elements cycle on and off to maintain the selected temperature. Convection baking is very consistent and even. The oven heats quickly, so preheating is not necessary or desirable. The fan circulates the hot air around the food making baked good rise quickly and evenly. Most baked goods are placed on the rack facing up in the lowest rack position. Your convection oven is designed to hold a half-sheet pan. There is no need to use the oven rack as your Teba oven has a inner heating element. The enameled tray included with your oven can also be used for baking.

- Place the enameled roasting/broiling pan or wire rack on the bottom rack position.
- Turn the function selector to "Bake" position and setting the thermostat to your desired oven temperature.
- Keep the oven door closed.
- Both the top and bottom heating elements are on
- Operation will not begin until the timer is set during use of any of the oven functions.

NOTE: Only the left hand burner on the range top will operate when using the "Bake" function.

Recommended Baking Temperatures.			
<i>Cakes:</i>	<i>325°-350°</i>	<i>Muffins:</i>	<i>400°</i>
<i>Cheesecake:</i>	<i>300°</i>	<i>Pies:</i>	<i>425°</i>
<i>Quick Bread:</i>	<i>375°</i>	<i>Cookies:</i>	<i>350°</i>

> **Rotisserie Roasting**

The top heating elements cycle on and off to maintain the maximum temperature in the oven. Rotisserie roasting is a healthy way to cook meats because the slow turning skewer provides natural basting of meats while fats drip away. The rotisserie can be used to roast meats up to 4 pounds and will easily handle a 4-pound chicken. Season your roast or chicken with your favorite seasonings as desired. It is not necessary to preheat the oven for rotisserie roasting.

- Place the rotisserie rack on the drip pan.
- Screw on the plastic handle on the rotisserie.



- Place one rotisserie fork on the end of the rotisserie opposite the point with the tines facing the center and tighten the screw slightly.
- Slide the pointed end of the rotisserie directly through the center of the meat.
- Place the other rotisserie fork on the other end of the rotisserie. Make sure the forks secure the roast or chicken on the skewer and tighten the screws.
- Place the skewer on the rotisserie rack
- Make sure the forks are not too close to the rotisserie rack and interfere with the movement of the meat.
- When cooking poultry, legs and wings should be secured to the body with string making the chicken as compact as possible. This is necessary for smooth movement of the rotisserie and prevents dragging.
- Season or baste the meat as desired.
- Remove the plastic handle.
- Place the drip pan directly on the bottom of the oven.
- Move the skewer hole cover, located on the right oven wall, either forward or backward, and insert the pointed end of skewer into the hole.
- Put the pointed end of the rotisserie in the drive socket on right interior wall of the oven.
- Turn the selector knob to "Rotisserie".
- When the meat is done, turn the timer knob and selector knob to the "0" position.
- Use the handling tool to remove the skewer from the hole by lifting the left end of the skewer and sliding it to the left as illustrated below.
- Remove the rotisserie from the oven-using handle included. (See below)
- Remove the roasting pan assembly from the oven using the tool provided.



- Reattach the plastic handle by turning it clockwise.
- Using a potholder, loosen the screws on the rotisserie forks and remove the rotisserie skewer from the meat. Carefully remove the rotisserie forks and carve the meat.
- Operation will not begin until the timer is set during use of any of the oven functions.

Caution: the rotisserie skewer, rotisserie forks, and screws will be hot.

NOTE: Only the left-hand burner on the ceramic range top will operate when using the "Rotisserie" function.

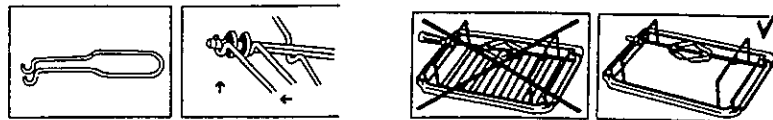

➤ **Broiling**

The top heating elements cycle on and off to maintain the maximum temperature in the oven.

For best results the oven should be preheated 20 minutes before adding the food to be broiled. In the convection oven, it is not necessary to turn food because the fan circulates the hot air around the food. The food must be placed on the broiling/roasting rack fitted into the drip/baking pan to allow the circulation of air.

If browned meats are desired, brush the surface with Worcester sauce or browning and seasoning sauce. Barbecue or other sweet sauces should be brushed on during the last 15 minutes of broiling. They will burn if applied too early in the cooking.

- Place the oven rack facing down in the center rack position.
- Turn the operation selector to "low broil" position for thinner pieces of food and light top browning or "High Broil" position for thicker pieces of meat.
- Keep the oven door in the one-third open position.
- Only the top heating element is on.
- The rotisserie motor will be engaged in the "High Broil" position. It is not necessary to use the rotisserie rack or skewer while broiling on "High Broil".
- Only the left-hand burner on the range top will operate when using the "Broil" functions.
- Operation will not begin until the timer is set during use of any of the oven functions.

➤ **Oven Burner**

Place our cooking pan directly on the bottom surface of the oven.

- Turn the operation selector to "Oven Burner" position.
- Only the bottom-heating element is on.
- Only the left-hand burner on the range top will operate when using the oven burner function.

➤ **Ceramic Range Top**

- Place your cooking pan on the desired burner.
- Turn the temperature control for the burners to the desired setting.
- There are 6 temperature settings from low (½) to high (3).
- Both burners may be used at the same time unless "Warm," "Bake," "Broil," "Oven Burner," and "Rotisserie," is being used. The right hand burner will be disabled when using one of these functions.
- Your Mini Kitchen has an additional residual heat indicator that illuminates as long as the ceramic range top is hot even if both cooking tops have already been turned off. As soon as the ceramic burner has cooled down the light goes out.

Note: Do not use pans with a diameter less than that of the burner. It is advisable to use pans, which have flat bottom of good thickness. The burners should not be used without a pot or pan on them. If any liquid spillage occurs it is recommended that the burners are wiped with a cloth.

➤ **Keep Warm**

- Position food in the oven.
- Turn the operation selector to "W" for keep warm.
- Set the timer to your desired cooking time or to "M" for manual time cooking.
- Keep the oven door closed.
- Only the left-hand burner on the ceramic range top will operate when using the "Keep Warm" function.

Note: do not keep foods warm for prolonged periods or use this feature to reheat frozen or cold foods.

CARE AND MAINTENANCE

The appliance should be cleaned regularly for long-term operating.

➤ Cleaning Your Mini-Kitchen

- Make sure that all parts of the oven are cool before cleaning.
- Turn the oven off, unplug the oven, and remove the shelves and trays.
- Using a wet rag wash the inside with warm water and a mild detergent.
- Wash the shelves and trays with a mild detergent solution.
- The glass oven door should be cleaned regularly with a non-abrasive liquid cleaner.
- Rinse with a damp cloth and then a dry one.
- The outside of the appliance should be cleaned with mild detergent and warm water.
- Occasionally wiping the surface of the burners with a trace of clean cooking oil will help to maintain their appearance.
- Do not use harsh abrasive cleaners on the enameled panels.

HELPFUL HINTS...

Aluminum: Medium-weight cookware is recommended because it heats quickly and evenly. Most foods brown evenly in an aluminum skillet. Use saucepans with tight-fitting lids when cooking with minimum amounts of water.

Cast-iron: If heated slowly, most skillets will give satisfactory results.

Enamelware: Under some conditions, the enamel of some cookware may melt. Follow cookware manufacturer's recommendations for cooking methods.

Glass: There are two types of glass cookware – those for oven use only and those for top-of-oven cooking (saucepans, coffee and teapots).

Heatproof Glass Ceramic: Can be used for either surface or oven cooking. It conducts heat very slowly and cools very slowly.

Stainless Steel: This metal alone has poor heating properties and is usually combined with copper, aluminum or other metals for improved heat distribution. Combination metal skillets generally work satisfactorily if used at medium heat as the manufacturer recommends.

RECIPES

Raisin Oatmeal Muffins

½ cup whole wheat flour	1 teaspoon salt
¾ cup white flour	1 cup buttermilk
¾ cups old-fashioned oats (oatmeal)	1 egg
¼ cup brown sugar, firmly packed	1 teaspoon vanilla
1 teaspoon cinnamon	¼ cup oil
2 teaspoons baking powder	1 cup raisins
1 teaspoon baking soda	

Spray a 12-cup muffin pan with cooking oil spray or line with cupcake liners. In a large mixing bowl combine dry ingredients. In another bowl combine, buttermilk, egg, vanilla and oil and slowly stir into the dry ingredients just until combined. Stir in the raisins. Fill the muffins cups to within ½ inch of the top. Place the muffin pan to the desired position. Set the oven to 400° and Bake for 18-22 minutes or until a toothpick inserted in the center comes out clean. Makes 12 muffins.

Blueberry Corn Muffins

1 cup yellow cornmeal	1/3 cup vegetable oil
1 cup flour	¾ cup milk
½ cup sugar	1 egg
1 tablespoon baking powder	½ cup fresh or frozen blueberries, unthawed
1 teaspoon salt	

Spray a 12-cup muffin pan with cooking oil spray or line with cupcake liners. In a large mixing bowl combine dry ingredients. In another bowl combine oil, milk and egg and slowly stir into the dry ingredients just until combined. Gently fold in the blueberries. Fill the muffin cups to within ½ inch of the top. Place the muffin pan in the oven. Set the oven to 400° and Bake for 18-20 minutes or until a toothpick inserted in the center comes out clean. Makes 12 muffins.

Pumpkin n' Pear Bread

1 can (15 ounces) pumpkin	½ teaspoon salt
¼ cup oil	2 tablespoons baking powder
2 eggs	1 teaspoon cinnamon
1 can (8.25 ounces) pears, with liquid, mashed	¼ teaspoon each nutmeg and allspice
1 ¼ cup brown sugar, firmly packed	½ cup chopped walnuts
4 cups flour	

Grease 2 (8 ½" x 4 ½" x 2") loaf pans. In a large mixing bowl combine pumpkin, oil, eggs, pears and brown sugar. In another mixing bowl combine the remaining ingredients. Stir the dry ingredients into the pumpkin mixture until all the flour is incorporated. Spoon batter into prepared pans. Place the pans in the oven. Set the oven to 375° and bake for 45-50 minutes or until a toothpick inserted in the center comes out clean. Makes 2 loaves.

Sour Cream Chocolate Cake

1 box (18.5 ounces) chocolate cake mix with pudding in the mix	½ cup oil
1 cup sour cream	4 eggs
1/3 cup water	1 cup semi-sweet chocolate chips

Grease a 10-inch bundt pan. In a large mixing bowl combine all ingredients, except chocolate chips, using a hand mixer at low speed. Continue to mix at medium speed for about 3 minutes. Stir in the chips. Spoon the batter into the prepared pan. Place the pan in the oven. Set the oven to 350° and bake for 45-50 minutes or until a toothpick inserted in the center comes out clean. Remove from the oven and allow to cool for 10 minutes. Turn the cake onto a serving dish. Cool and sprinkle with powdered sugar. Makes 1 bundt cake.

Note: To make Chocolate Chip Butter Pound Cake: substitute recipe yellow butter cake mix using 1 box (4 serving size) instant vanilla pudding for the chocolate cake mix. Use ½ cup butter in place of oil. Follow the recipe as given.

Strawberry Apple Pie

1 pint strawberries, hulled and sliced	¼ cup flour
3 tart cooking apples, peeled and thinly sliced	½ teaspoon cinnamon
1 cup sugar	Pastry for a 2-crust pie

In a large mixing bowl combine the berries, apples, sugar, flour and cinnamon. Fit one of the piecrusts into a 9-inch metal pie plate. Spoon the fruit mixture into the crust mounding the fruit in the center and top with the second crust. Fold the edges of the top crust under the bottom crust, seal, and flute the edges. Make several slits in the top of the pie to vent the steam. Place a cookie sheet under the pie to catch any dripping. Place the cookie sheet in the oven. Set the oven to 425° and bake for 45-50 minutes or until golden brown. Makes 1 pie.

Easy Dinner Rolls

1 cup plus 2 tablespoons warm water	3 cups bread flour
1/3-cup butter, cut in pieces	3 tablespoons sugar
1 egg	1 teaspoon salt
3 tablespoons mashed potato flakes	1 envelope active dry yeast

Place all the ingredients in the order listed into the bread pan of an automatic bread machine. Set machine on the dough or manual cycle and press start. When the cycle is complete remove the dough and allow it to stand for 10 minutes. Sprinkle a small amount of flour on a cutting board. Cut the dough in half and roll into two 12-inch ropes. Cut each rope into 12 equal-sized pieces. If the dough becomes sticky while shaping, knead in additional flour. Shape the dough into balls. Spray the baking pan with cooking oil spray. Place the rolls on the pan ½ inch apart. Place pan in the desired position. Set the oven to 175° and allow to rise for 15 minutes or until double in bulk. Raise the temperature to 400° F. and Bake for 12-15 minutes or until golden brown and the rolls sound hollow when tapped. Makes 24 rolls.

Chocolate Twirl Cheesecake

36 (cream filled) chocolate sandwich cookies	2 teaspoons vanilla
½ cup melted butter or margarine	1 cup sour cream
3 packages (8 ounces each) cream cheese, at room temperature	1 teaspoon lemon juice
4 eggs, at room temperature	2 tablespoons flour
1 cup sugar	¼ cup chocolate syrup

Crush cookies using a food processor or a rolling pin. Stir melted butter into the crumbs. Spoon the crumb mixture into a 13" x 9" x 2" baking pan and cover with plastic wrap. Press evenly into the bottom of the pan. Remove plastic wrap. In a large mixing bowl, using a mixer at medium speed, blend together the cream cheese and eggs. Mix until smooth. Add sugar, vanilla, sour cream, lemon juice and flour Mix until well combined. Pour the mixture into the prepared pan. Pour the chocolate syrup over the cake in an S pattern. Using a knife inserted ¼ inch into batter swirl the chocolate into the cake batter. Place pan in the desired position. Set the oven to 300° and Bake for 50-60 minutes or until a knife inserted 1-inch from the center comes out clean. Turn heat control to "Off" and allow the cake to cool in oven for 20 minutes. Refrigerate at least 4 hours. Makes 1 cake.

Chocolate and Vanilla Chunk Cookies

¼ cup butter	1 1/3 cup all-purpose flour
¾ cup brown sugar	1/3 teaspoon baking soda
¼ cup sugar	1/3 teaspoon salt
1 egg	¾ cup jumbo chocolate chips
1 teaspoon vanilla	¼ cup vanilla chips

In a mixing bowl, cream the butter and the sugars using an electric mixer add the egg and vanilla and beat well. Combine the flour, baking soda, and salt and add to the bowl mixing well on low speed. Stir in the chips. Pack a small ice cream scoop or a 1/4-cup measure with dough. Drop the cookie dough on the ungreased baking pan. Place the pan to the desired position. Set the oven to 325° and Bake for 18-22 minutes or until the cookies are lightly browned. Makes 24 cookies.

Holiday Turkey

16 to 22-pound turkey,
Worcestershire sauce
Seasoned salt

2-3 teaspoons cornstarch
1-teaspoon browning and seasoning sauce
¼ cup water

Remove neck and giblet packet from the turkey and discard or save for another use. Rinse turkey well. Rub a small amount of Worcestershire sauce into the skin and sprinkle with seasoning salt or your favorite combination of herbs. Insert an oven thermometer in the thickest part of the breast near the leg. Calculate the approximate cooking time at 15 minutes per pound. Place the turkey directly on the broiling/roasting rack in the drip/baking pan. Set the oven to 325° and Roast for 4 - 5 hours. Check the temperature on the meat thermometer occasionally. Continue to cook until the thermometer reads 170° or the pop up timer pops. Remove the turkey. Allow the turkey to stand for about 15 minutes before carving. The turkey will continue to cook and the thermometer should read 180° before carving. Skim the fat Trim the juices that have accumulated in the pan. Pour these drippings into a small saucepan and add about 1 tablespoon of cornstarch and the browning and seasoning sauce dissolved in 1/4 cup of water. ** Cook 5 minutes or until the gravy boils and thickens slightly. Pour the gravy into a pitcher and serve with the sliced turkey. Makes 16-24 servings.

* If the turkey is stuffed, roast 20 minutes per pound

** If more gravy is desired add an envelope of turkey gravy mix dissolved in 1 cup of water or a can of prepared gravy to the drippings at this time.

Smoked Ham and Yam

1 half (6-8 pound) or whole (12-16 pound) smoked ham, bone in
1/2 cup sweet and sour sauce
1 tablespoon raspberry or strawberry jam

1/2 cup orange juice
1 cup ginger ale
2 tablespoons cornstarch
6 medium-size yams (about 2 pounds)

Combine the sauce, jam, juice, ginger ale, and cornstarch. Set aside. Place the ham directly on the broiling/roasting rack in the drip/baking pan. Insert a meat thermometer into the center of the ham away from the bone. Calculate the approximate cooking time at 15 minutes per pound. Set the oven to 325° and Roast 1 ½ to 2 hours. Check the temperature on the meat thermometer occasionally. One hour before the ham is done, place the yams on the rack around the ham and brush the sauce on the ham. Pour the remaining sauce into the pan. Continue to cook until the thermometer reads 140° for fully cooked ham and 160° for uncooked ham. Remove the ham to a board and allow to stand for 10 minutes before carving. Wrap the yams in Toil to keep warm while carving the ham. Skim fat from sauce or pour into a fat separator to remove. Pour the sauce into a pitcher and serve with the sliced ham. Makes 6 to 18 servings, depending on the size of the ham.

Roasted Chicken and Apple Bread Stuffing with New Potatoes

2 tablespoons butter or margarine
1 tart cooking apple, peeled and cut into chunks
1 onion, chopped
4 cups dry bread-stuffing mix
1-cup applesauce or apple juice
6- to 8-pound roasting chicken

Paprika, onion powder, and garlic salt, to taste
8 new potatoes
2-3 teaspoons cornstarch
1-teaspoon browning and seasoning sauce or Worcestershire sauce
1/4 cup water

In a 10-inch fry pan melt the butter and sauté the apple and onion until nicely browned. Stir in the stuffing mix, applesauce and water Allow the stuffing to cool slightly and then spoon into the cavity of the chicken. Sprinkle the skin of the chicken with seasonings. Calculate the approximate cooking time at 25 minutes per pound. * Place the chicken directly on the broiling/roasting rack in the drip/baking pan. Slide the pan into the rails. Set the oven to 325° and Roast 2 - 2 1/2 hours. About 45 minutes before the chicken is scheduled to be done, place the potatoes on the rack around the chicken. Check the temperature on the meat thermometer occasionally. Continue to cook until the thermometer read 170°. Remove the chicken.

Allow the chicken to stand for about 15 minutes before carving. The chicken will continue to cook and the thermometer should read 180° before carving. Skim the fat from the juices that have accumulated in the pan. Pour the drippings into a small saucepan add about 1 tablespoon of cornstarch and browning and seasoning sauce dissolved in 1/4 cup of water to the drippings to thicken the gravy Cook 5 minutes or until the gravy boils and thickens slightly. Pour the gravy into a pitcher and serve with the sliced chicken. Makes 6 servings.

*If the chicken is unstuffed roast 20 minutes per pound.

**If more gravy is desired add an envelope of chicken gravy mix dissolved in 1 cup of water or a can of prepared gravy to the drippings at this time.

Corn Bread Stuffed Pork Loin

1 bag (6 ounces) corn bread stuffing mix
1 can (14 ounces) chicken broth
1 cup orange juice
2 tablespoons melted butter
1 bag (6 ounces) dried mixed fruit bits or assorted whole dried fruits, chopped

6- to 8-pound whole boneless loin of pork
1 envelope of pork gravy mix dissolved in 1 cup of water

Combine all the ingredients except the pork and the gravy mix. Place the pork fat side down on a cuffing board. Make slits 1 inch apart in the pork cuffing down to within a 1/2-inch of the fat to form a pocket for the stuffing. Be careful not to cut through. Spoon about 1/2 cup of the stuffing into each pocket. Place the roast directly on the broiling/roasting rack in the drip/baking pan. Place a meat thermometer into the center of one of the pork slices. Calculate the approximate cooking time at 15 minutes per pound. Set the oven to 350° and Roast 1 1/2 - 2 hours. The meat is done when the thermometer reaches 170°. Skim the fat from the juices that have accumulated in the drip pan. Pour these drippings into a small saucepan and add the gravy mix. Cook 5 minutes or until the gravy boils and thickens slightly. Pour the gravy into a pitcher and serve with the sliced pork. Makes 10-14 servings.

Roast Beef with Twice-Baked Cheesy Potatoes

4 to 6-pound boneless sirloin tip roast
Worcestershire sauce
Garlic powder, paprika and dried onion to taste
8 medium-size baking potatoes (about 3 pounds)
4 ounces grated cheddar cheese
4 ounces grated mozzarella
2 tablespoons Parmesan

1/2 cup sour cream
1/4 cup milk
1 teaspoon garlic powder
1 can of beef gravy or 1 envelope of gravy mix dissolved in 1 cup water

Rub the surface of the meat with Worcestershire sauce and then sprinkle with garlic, paprika, and dried onion. Calculate the approximate cooking time at 20-22 minutes per pound for rare, 23-24 minutes per pound for medium and 25-27 minutes per pound for well done. Place a meat thermometer in the thickest part of the roast. Place the roast fat side up, on the broiling/roasting rack in the drip/baking pan. Place the potatoes on the rack around the roast. Set the oven to 350° F Slide the pan into the rails. Roast for 1 hour 20 minutes to 3 hours and 20 minutes. Check the meat thermometer reading occasionally. Continue to cook until the thermometer reads rare (120°-130°), medium (140°) or well done (160°-170°). After 1 hour remove potatoes to a cuffing board and allow to cool for about 15 minutes. Slice a small piece off the top of each potato. Scoop out the potato from the skins and place in a medium-mixing bowl. Reserve skins. Add the cheese, sour cream, milk, and garlic powder to the mixing bowl and blend, with a hand mixer; until the mixture is smooth. Spoon the potato mixture in the potato skins, sprinkle each with paprika and place the prepared potatoes on the rack with the roast 30 minutes before the roast is done. Remove the roast to a cutting board and allow to stand about 10 minutes. Skim the fat from the juices that have accumulated in the drip tray. Pour the drippings into a small saucepan along with the prepared gravy. Cook for 5 minutes or until the gravy thickens. Pour the gravy into a pitcher and serve with the sliced beef. Makes 8-12 servings, depending on the size of the roast.

Turkey 'n Beef Meat Loaf Dinner

1 pound groundturkey
1/2 pound ground beef
1 egg
1/2 cup flavored breadcrumbs
1 envelope (1.2 ounces) dried onion soup mix
1/3 cup catsup
1/4 cup water
3 slices American cheese

Worcestershire sauce
3 slices pork or turkey bacon cut in half
3 medium potatoes cut in 1/8's
2 medium onions cut in 1/8's
8 ounces baby carrots
salt, pepper, herbs and spices, to taste

In a medium mixing bowl combine the meats, egg, bread crumbs onion soup mix, catsup, and water. Mix well and put 1/2 of the mixture on the drip/baking pan. Press the cheese in the center of the meat and cover with the remaining meat mixture. Form into an oblong loaf making sure that the cheese is sealed into the meat. Sprinkle Worcestershire sauce over the meat. Place the bacon on the top of the meat loaf. Arrange the potatoes and vegetables around the meat loaf and sprinkle with salt, pepper and any herbs or spices you like. Place the pan on the rack in the lowest rack position with rack facing up. Set the oven to 350° and Bake for 50-60 minutes or until the meat loaf and potatoes are nicely browned. Makes 6-8 servings.

Corn Bread Stuffed Pork Loin

1 bag (6 ounces) corn bread stuffing mix
1 can (14 ounces) chicken broth
1 cup orange juice
2 tablespoons melted butter
1 bag (6 ounces) dried mixed fruit bits or assorted whole dried fruits, chopped

6- to 8-pound whole boneless loin of pork
1 envelope of pork gravy mix dissolved in 1 cup of water

Combine all the ingredients except the pork and the gravy mix. Place the pork fat side down on a cuffing board. Make slits 1 inch apart in the pork cuffing down to within a 1/2-inch of the fat to form a pocket for the stuffing. Be careful not to cut through. Spoon about 1/2 cup of the stuffing into each pocket. Place the roast directly on the broiling/roasting rack in the drip/baking pan. Place a meat thermometer into the center of one of the pork slices. Calculate the approximate cooking time at 15 minutes per pound. Set the oven to 350° and Roast 1 1/2 - 2 hours. The meat is done when the thermometer reaches 170°. Skim the fat from the juices that have accumulated in the drip pan. Pour these drippings into a small saucepan and add the gravy mix. Cook 5 minutes or until the gravy boils and thickens slightly. Pour the gravy into a pitcher and serve with the sliced pork. Makes 10-14 servings.

Roast Beef with Twice-Baked Cheesy Potatoes

4 to 6-pound boneless sirloin tip roast
Worcestershire sauce
Garlic powder, paprika and dried onion to taste
8 medium-size baking potatoes (about 3 pounds)
4 ounces grated cheddar cheese
4 ounces grated mozzarella
2 tablespoons Parmesan

1/2 cup sour cream
1/4 cup milk
1 teaspoon garlic powder
1 can of beef gravy or 1 envelope of gravy mix dissolved in 1 cup water

Rub the surface of the meat with Worcestershire sauce and then sprinkle with garlic, paprika, and dried onion. Calculate the approximate cooking time at 20-22 minutes per pound for rare, 23-24 minutes per pound for medium and 25-27 minutes per pound for well done. Place a meat thermometer in the thickest part of the roast. Place the roast fat side up, on the broiling/roasting rack in the drip/baking pan. Place the potatoes on the rack around the roast. Set the oven to 350° F Slide the pan into the rails. Roast for 1 hour 20 minutes to 3 hours and 20 minutes. Check the meat thermometer reading occasionally. Continue to cook until the thermometer reads rare (120°-130°), medium (140°) or well done (160°-170°). After 1 hour remove potatoes to a cuffing board and allow to cool for about 15 minutes. Slice a small piece off the top of each potato. Scoop out the potato from the skins and place in a medium-mixing bowl. Reserve skins. Add the cheese, sour cream, milk, and garlic powder to the mixing bowl and blend, with a hand mixer, until the mixture is smooth. Spoon the potato mixture in the potato skins, sprinkle each with paprika and place the prepared potatoes on the rack with the roast 30 minutes before the roast is done. Remove the roast to a cutting board and allow to stand about 10 minutes. Skim the fat from the juices that have accumulated in the drip tray. Pour the drippings into a small saucepan along with the prepared gravy. Cook for 5 minutes or until the gravy thickens. Pour the gravy into a pitcher and serve with the sliced beef. Makes 8-12 servings, depending on the size of the roast.

Turkey 'n Beef Meat Loaf Dinner

1 pound groundturkey
1/2 pound ground beef
1 egg
1/2 cup flavored breadcrumbs
1 envelope (1.2 ounces) dried onion soup mix
1/3 cup catsup
1/4 cup water
3 slices American cheese

Worcestershire sauce
3 slices pork or turkey bacon cut in half
3 medium potatoes cut in 1/8's
2 medium onions cut in 1/8's
8 ounces baby carrots
salt, pepper, herbs and spices, to taste

In a medium mixing bowl combine the meats, egg, bread crumbs onion soup mix, catsup, and water. Mix well and put 1/2 of the mixture on the drip/baking pan. Press the cheese in the center of the meat and cover with the remaining meat mixture. Form into an oblong loaf making sure that the cheese is sealed into the meat. Sprinkle Worcestershire sauce over the meat. Place the bacon on the top of the meat loaf. Arrange the potatoes and vegetables around the meat loaf and sprinkle with salt, pepper and any herbs or spices you like. Place the pan on the rack in the lowest rack position with rack facing up. Set the oven to 350° and Bake for 50-60 minutes or until the meat loaf and potatoes are nicely browned. Makes 6-8 servings.

Moroccan-Style Leg of Lamb with Couscous and Vegetables

1 tablespoon Dijon mustard	1 teaspoon salt
1 tablespoon lemon juice	¼ teaspoon pepper
Garlic powder; onion powder; paprika to taste	1 can (15 ounces) chickpeas with liquid
6- to 8-pound leg of lamb	1 can (14 ounces) beef broth
¼ cup oil	1 can (16 ounces) stewed tomatoes
1 medium onion, chopped	2 cups Couscous
1 eggplant, peeled and cut into 1-inch cubes	1 can or 1 envelope brown gravy mix, prepared as directed
2 carrots, chopped	
2 stalks celery, chopped	
1 teaspoon dried basil	

Combine the mustard and lemon juice and brush it on both sides of the lamb. Sprinkle with garlic, onion, and paprika. Insert a meat thermometer into the center of the lamb away from the bone. Calculate the approximate cooking time at 25 minutes per pound. Place the roast, fat side up, directly on the broiling/roasting rack, in the drip/baking pan. Set the oven to 350° and Roast 2 ½ to 3 hours. Check the temperature on the meat thermometer occasionally. Continue to cook until the lamb has reached desired temperature: (rare) 160°, (medium) 170°, or (well-done) 180°. About 20 minutes before the roast is done, sauté the onions in oil in a 3-quart saucepan until lightly browned about 3 minutes. Add the carrots and celery and sauté 2 minutes. Stir in the eggplant and the remaining ingredients. Cook for 15 minutes or until the vegetables are tender and the Couscous has absorbed most of the liquid. Remove the lamb and the rack and place the lamb on a cutting board. Allow the meat to stand for about 10 minutes before carving. Skim the fat from the drippings that have accumulated in the pan. Pour these drippings into a small saucepan with the water and gravy mix. Cook 5 minutes or until the gravy boils and thickens. Slice meat and serve with the gravy, Couscous, and vegetables. Makes 12 servings.

Chicken and Pasta Casserole

12 ounces bow tie pasta	chicken cut into bite size pieces
2 tablespoons olive oil	1 tablespoon basil
1 large onion, chopped	1 tablespoon dried parsley
2 cloves garlic, crushed	1 jar (28 ounces) tomato sauce
1 medium red pepper, chopped	1 teaspoon salt
1 package (10 ounces) fresh mushroom slices	¼ teaspoon pepper
1 ½ pounds boneless white or dark meat	2 tablespoon grated Parmesan cheese
	8 ounces grated mozzarella

Cook the pasta according to package directions. Drain and spoon into a 3-quart casserole. Heat the oil in a 10-inch fry pan and sauté the onion for 3 minutes. Add the garlic, red pepper and mushrooms, sauté until the mushrooms are limp about 3 minutes. Spoon the contents of the fry pan into the casserole with the pasta. Add remaining ingredients except the cheeses. Stir well to combine. Sprinkle the cheeses on top of the casserole. Place pan in the desired position. Set the oven to 350° and Bake for 30 minutes or until the casserole is hot and the cheeses are melted and brown. Makes 8-12 servings.

Chicken Pot Pie

2 pounds boneless white meat chicken cut into 3/4-inch chunks	1 package (10 ounces) frozen peas and carrots, defrosted
3 stalks celery, with leaves	2 teaspoons minced dried onion
1 can (10 ¾ ounces) cream of mushroom soup	1 teaspoon garlic powder
1 envelope (1.8 ounces) white sauce mix, dissolved in 1/2 cup milk	1-tablespoon parsley flakes
1 can (15.25 ounces) whole kernel corn, drained	¼ teaspoon thyme
	2 ready-to-bake pie crusts

Place all of the ingredients except the piecrusts into a 13" x 9" x 2" baking pan. On a lightly floured board roll both of the piecrusts together to form one 15" x 11" crust. Place the crust over the mixture in the pan. Roll the edges and pinch together making sure to completely cover the filling ingredients. Cut a few slits in the crust to allow the steam to vent. Place pan in the desired position. Bake at 425° for 45-55 minutes or until golden brown. Makes 8-12 servings.

Turkey, Vegetable and Stuffing Bake

1 pound cooked* turkey (or chicken), about 4 cups	1 tablespoon Worcestershire sauce
1 package (16 ounces) frozen mixed vegetables, thawed	4 ounces grated cheddar cheese
1 can (10.75 ounces) cream of mushroom soup	2 1/2 cups dry bread-stuffing mix
1 teaspoon garlic powder	1 tablespoon melted margarine
1/2 teaspoon onion powder	1 cup water
	1 cup turkey or chicken gravy

Combine the first seven ingredients in a 13" x 9" x 2" baking dish. In a small bowl combine the stuffing mix, butter and water. Top the turkey vegetable mixture with the stuffing and pour the gravy over all. Place pan in the desired position. Set the oven to 350° F. and bake for 35-40 minutes or until the stuffing is browned and the casserole is heated through. Makes 8-12 servings.

* Raw chicken can be substituted for cooked. Bake for an additional 10 minutes.

Herb Marinated Chicken

2 tablespoons grated Parmesan cheese	1 teaspoon paprika
2 tablespoons olive oil	1 teaspoon Dijon mustard
2 tablespoons lemon juice	1/8 teaspoon each dill, thyme, sage
1 teaspoon chopped parsley	4-pound broiler fryer chicken cut in half
1 teaspoon chopped chives	

Set the temperature control to Max and the function control to Broil. Preheat for 20 minutes. Combine all ingredients except chicken in a gallon-size sealable plastic bag. Add the chicken and seal. Marinate at room temperature while the oven is preheating. Remove the chicken from the bag and place it on the broiling/roasting rack in the drip/baking pan. Pour the extra marinade over the chicken. Slide the pan onto the oven rack in the middle rack position facing down. Broil for 30-40 minutes or until skin is crisp and well browned. Makes 2-4 servings.

Honey Mustard Roasted Chicken

2 tablespoons honey	1 teaspoon each crushed rosemary and sage
1 tablespoon Dijon mustard	1/2 teaspoon each onion and garlic powder
1 teaspoon lemon juice	2 (3-4 pounds each) whole chickens
1 tablespoon mayonnaise	

Place one fork onto the spit and tighten down the screw to fasten it in place. Place the spit through the neck hole. Pierce the skin with the fork and secure it in the surrounding meat. Repeat with the second chicken. Place the second fork onto the spit and press it into the legs of the second chicken. Push them together and tighten the screw on the second fork. Center the chicken on the spit by loosening the screws and retightening where needed. Re-adjust the chickens if necessary to be sure they are balanced. * Insert the pointed end of the spit into the right hand side of the drive socket. The left hand side (the grooved side) rest on the spit support. Place pan in the desired position. Set the temperature control to Max and the function control to Rotisserie. Cook for 1 hour Remove the chicken with the rotisserie handle and brush the skin with the honey mustard glaze. Check for doneness by inserting a meat thermometer into the area between the leg and breast of one of the chickens. It is done when the thermometer reads 180°. Continue to cook 10 minutes for each 10° needed.

Barbecue Beef Roast

- | | |
|--------------------------------------|---------------------------------|
| ¼ cup catsup | 1 teaspoon onion powder |
| 2 tablespoons soy sauce | ¼ teaspoon garlic powder |
| 2 tablespoons honey | 4- to 5-pound top sirloin roast |
| 1-2 teaspoons liquid smoke flavoring | |

Combine all the ingredients except the meat in a small saucepan and bring to a boil. Reduce heat and simmer 10 minutes. Allow the sauce to cool. Place one fork onto the spit and tighten down the screw to fasten it in place. Insert the spit into the center of meat and place the other fork onto the spit. Press it into the meat. Re-adjust the meat until it is in the center of the spit. Insert the pointed end of the spit into the right-hand side of the drive socket. The left hand-side (the grooved side rests on the spit support. Place pan in the desired position. Set the temperature control to Max and the function control to Rotisserie. Cook 1 hour. Brush with barbecue sauce. Check for doneness by inserting a meat thermometer into thickest part of the meat. Do not touch the spit with the thermometer. Continue to cook 10 minutes for each 10°-needed Rare (120°- 130°), Medium (140°- 150°) or Well (160°- 170°).

Spicy Slow-Cooked Two Bean and Sausage Soup

- | | |
|--|--|
| 1 pound hot Italian sausage, casings removed | 2 cans (15 ½ ounces each) chick peas with liquid |
| 1 large onion, chopped | 2 pounds lentils, rinsed and drained |
| 1 teaspoon garlic powder | 2 packages (10 ounces each) frozen chopped spinach, thawed |
| 1 teaspoon salt | 1 jar (20 ounces) salsa |
| ½ -1 teaspoon ground red pepper | 1 pound boneless chicken thighs |
| 3 stalks celery | |
| 3 carrots, chopped | |

Sauté the sausage in a 10-inch fry pan until lightly browned. Stir in the onions and sauté until browned. Spoon the sausage and onions into a 3-quart casserole. Add the remaining ingredients and cover. Place the casserole to the desired position. Set the oven to 250° and Slow Cook for 4-6 hours. Makes 12 servings.

Pot Roast Dinner

- | | |
|---|---|
| 2 tablespoons flour | 1 can (14 ounces) beef broth |
| 1 teaspoon each of garlic powder, onion powder, and paprika | 2 tablespoons minced dry onions |
| 1(4-6 pound) bottom round roast | 1 envelope (1.5 ounces) beef stew seasoning mix |
| 1 tablespoon oil | ½ pound carrots, peeled and cut in 1/3's |
| 1 tablespoon Worcestershire sauce | 1 ½ pounds potatoes cut in ¼'s |
| 1 cup water | 1 cup water |

Combine the flour and seasonings in a plastic bag. Place the roast into the bag and shake to coat. Brown the coated roast on all sides in the oil in a 10-inch fry pan. Place the roast into a 3-quart casserole dish along with the Worcestershire sauce, water, beef broth, onion soup, and stew seasoning mix. Cover. Place the casserole on the oven rack in the lowest rack position facing up. Set the oven to 250° and Slow Cook for 4-6 hours. Add the vegetables and remaining water if needed. Turn the heat control dial to 350° and cook until the vegetables are tender; about 1 hour remove the roast from the casserole and allow it to cool for 10 minutes before slicing. Slice and serve with the vegetables and gravy. Makes 8-12 servings.

PROBLEMS WITH YOUR APPLIANCE?

You can solve many common appliance problems easily, saving you the cost of a possible service call. Try the suggestions below to see if you can solve the problem before calling the servicer.

TROUBLESHOOTING GUIDE

FIND YOUR PROBLEM HERE	POSSIBLE CAUSE	HOW TO FIX IT
Oven or broiler does not heat.	<ul style="list-style-type: none"> ❖ Temperature control not set properly. ❖ House fuse has blown or circuit breaker has tripped. ❖ Oven cord is disconnected from outlet. ❖ Timer is not in operation. 	<ul style="list-style-type: none"> ❖ Make sure temperature control is set at desired temperature. ❖ Check/reset circuit breaker and/or replace fuse. Do not increase fuse capacity. If the problem is a circuit overload, have it corrected by a qualified electrician. ❖ Be sure the power cord is plugged into a grounded outlet. ❖ Be sure the timer is not on "0". The oven will not operate unless the timer is set.
Oven temperature is not hot enough.	<ul style="list-style-type: none"> ❖ Temperature control not set properly. ❖ Improper use of foil. 	<ul style="list-style-type: none"> ❖ Make sure the temperature control knob is set at the desired temperature. ❖ Keep foil clear of holes in oven bottom and off of oven racks.
Oven burner cycles on and off.	<ul style="list-style-type: none"> ❖ This is normal. 	
Smoke or odor on initial oven operation.	<ul style="list-style-type: none"> ❖ This is normal. 	
Oven smokes excessively.	<ul style="list-style-type: none"> ❖ Meat too close to broiler burner. ❖ Meat not prepared properly. 	<ul style="list-style-type: none"> ❖ Reposition the broiler pan to provide more clearance between the meat and the broiler burner ❖ Remove excess fat from meat.

PROBLEMS WITH YOUR APPLIANCE?

You can solve many common appliance problems easily, saving you the cost of a possible service call. Try the suggestions below to see if you can solve the problem before calling the servicer.

TROUBLESHOOTING GUIDE

FIND YOUR PROBLEM HERE	POSSIBLE CAUSE	HOW TO FIX IT
Oven or broiler does not heat.	<ul style="list-style-type: none"> ❖ Temperature control not set properly. ❖ House fuse has blown or circuit breaker has tripped. ❖ Oven cord is disconnected from outlet. ❖ Timer is not in operation. 	<ul style="list-style-type: none"> ❖ Make sure temperature control is set at desired temperature. ❖ Check/reset circuit breaker and/or replace fuse. Do not increase fuse capacity. If the problem is a circuit overload, have it corrected by a qualified electrician. ❖ Be sure the power cord is plugged into a grounded outlet. ❖ Be sure the timer is not on "0". The oven will not operate unless the timer is set.
Oven temperature is not hot enough.	<ul style="list-style-type: none"> ❖ Temperature control not set properly. ❖ Improper use of foil. 	<ul style="list-style-type: none"> ❖ Make sure the temperature control knob is set at the desired temperature. ❖ Keep foil clear of holes in oven bottom and off of oven racks.
Oven burner cycles on and off.	<ul style="list-style-type: none"> ❖ This is normal. 	
Smoke or odor on initial oven operation.	<ul style="list-style-type: none"> ❖ This is normal. 	
Oven smokes excessively.	<ul style="list-style-type: none"> ❖ Meat too close to broiler burner. ❖ Meat not prepared properly. 	<ul style="list-style-type: none"> ❖ Reposition the broiler pan to provide more clearance between the meat and the broiler burner ❖ Remove excess fat from meat.

SERVICE FOR YOUR MINI-KITCHEN

We are proud of our customer service organization and the network of professional service technicians that provide service on your Avanti appliances. With the purchase of your Avanti appliance, you can have the confidence that if you ever need additional information or assistance, the Avanti Products Customer Service team will be here for you. Just call us toll-free.

AVANTI PRODUCTS CUSTOMER SERVICES

Product Information 800-323-5029	Whatever your questions are about our products, help is available.
Part Orders 800-220-5570	You may order parts and accessories that will be delivered directly to your home. You may order these items by personal check, money order, Master Card, or Visa.
In-Home Repair Service 800-220-5570	An Avanti Products authorized service center will provide expert repair service, scheduled at a time that is convenient for you. Our trained Servicicers know your appliance inside and out.

Warranty Information

Thank you for purchasing this fine Avanti product. Please fill out this card and return it within 100 days of purchase and receive these important benefits:

- **Confirm your warranty:**
Your prompt product registration confirms your right to the protection available under the terms and conditions of your Avanti warranty.

- **Protect your product:**
We will keep the model number and date of purchase of your new Avanti product on file to help you refer to this information in the event of an insurance claim such as fire or theft.

- **Promote better products:**
We value your input. Your responses will help us develop products designed to best meet your future needs.

----- (detach here) -----

Avanti Registration Card

Name _____	Model # _____	Serial # _____
Address _____	Date Purchased _____	Store/Dealer Name _____
City _____ State _____ Zip _____	Occupation _____	

Area Code _____ Phone Number _____

Did You Purchase An Additional Warranty:

Extended Food Loss None

Reason For Choosing This Avanti Product:

Please indicate the most important factors that influenced your decision to purchase this product.

- Price
- Product Features
- Avanti Reputation
- Product Quality
- Salesperson Recommendation
- Friend/Relative Recommendation
- Warranty
- Other _____

As Your Primary Residence, Do You:

Own Rent

Your Age:

under 18 18-25 26-30
 31-35 36-50 over 50

Marital Status:

Married Single

Is This Product Used In The:

Home Business

How Did You Learn About This Product:

Advertising Product Features
 In Store Demo Personal Demo
 Other _____

Comments _____

HELP US HELP YOU...

Read this guide carefully.

It is intended to help you operate and maintain your new Mini-Kitchen properly.

Keep it handy to answer your questions. If you don't understand something or you need more help, please call:

**Avanti Customer Service
800-220-5570**

Keep proof of original purchase date (such as your sales slip) with this guide to establish the warranty period.

Write down the model and serial numbers.

You'll find them on a plate located on the left wall inside the Mini-Kitchen.

Please write these numbers here:

Date of Purchase

Model Number

Serial Number

Use these numbers in any correspondence or service calls concerning your Mini-Kitchen.

If you received a damaged Mini-Kitchen, immediately contact the dealer (or builder) that sold you the Mini-Kitchen.

Save time and money. Before you call for service, check the Problem Solver Guide. It lists causes of minor operating problems that you can correct yourself.

IF YOU NEED SERVICE

We're proud of our service and want you to be pleased. If for some reason you are not happy with the service you receive, here are some steps to follow for further help.

FIRST, contact the people who serviced your appliance. Explain why you are not pleased. In most cases, this will solve the problem.

NEXT, if you are still not pleased, write all the details, including your telephone number, to:

**Customer Service
Avanti Products
10880 NW 30 Street
Miami, FL 33172**