

WD-210卧式冷柜爆炸图

Explosive Drawing-210

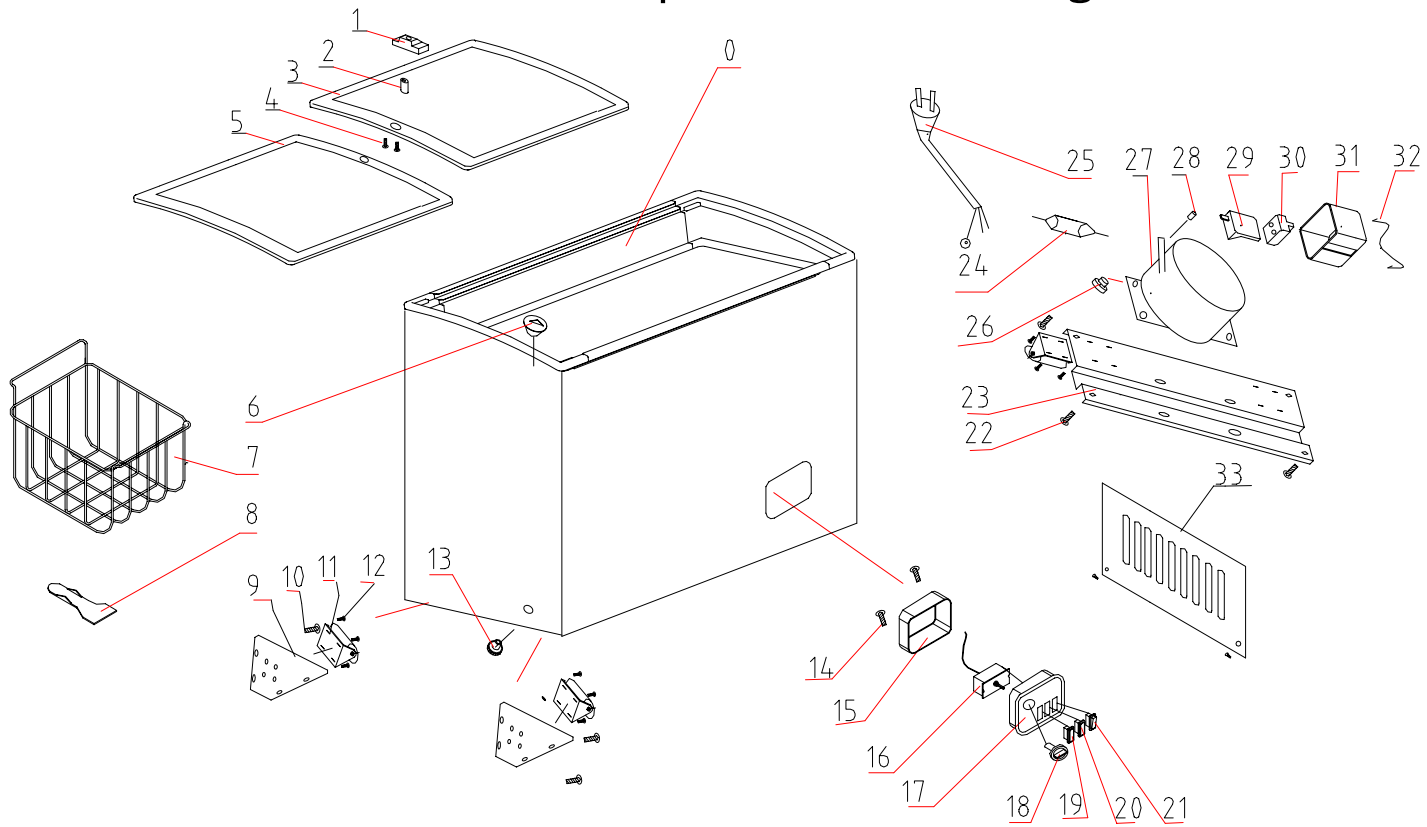

W D-2 1 0 冷柜

| NO | 图号 | 名称 | 英文名称 | 数量 | 单价价格(美元) |
|----|-------------|-------|---------------------|----|----------|
| 0 | B209.3 | 箱体部件 | Cabinet | 1 | 71.3 |
| 1 | B209.2-2 | 锁盒 | lock cover | 1 | 0.1 |
| 2 | B209.2-1 | 锁 | lock | 1 | 4.9 |
| 3 | B209.1 | 上门 | up door | 1 | 63.6 |
| 4 | | 自攻螺钉 | Screw | 2 | |
| 5 | B209.1 | 下门 | down door | 1 | 63.6 |
| 6 | B205.7.4-4 | 内出水管盖 | Inner Cover | 1 | 0.1 |
| 7 | B209.0-3 | 吊篮 | Rack | 3 | 4.4 |
| 8 | B101.7-10 | 冰铲 | Ice Shovel | 1 | 0.2 |
| 9 | B205.7.1-10 | 角板 | Cabinet Base | 2 | 0.5 |
| 10 | | 自攻螺钉 | Screw | 8 | |
| 11 | B205.3 | 脚轮 | Leg | 4 | 0.8 |
| 12 | | 螺栓 | Screw | 16 | |
| 13 | B205.7.4-1 | 出水管盖 | Cover | 1 | 0.1 |
| 14 | | 自攻螺钉 | Screw | 2 | |
| 15 | B205.1-6 | 温控器盒 | THERMOSTAT COVER | 1 | 0.6 |
| 16 | B205.1-2 | 温控器 | THERMOSTAT | 1 | 1.9 |
| 17 | B205.1-1 | 控制面板 | Control Board | 1 | 0.7 |
| 18 | B101.0-1 | 温控旋钮 | Thermostat Knob | 1 | 0.1 |
| 19 | B205.1-3 | 电源指示灯 | Power Light | 1 | 0.6 |
| 20 | B205.1-3 | 运行指示灯 | Opertion Light | 1 | 0.6 |
| 21 | B205.1-4 | 急冷开关 | Fast Freezer Switch | 1 | 1.1 |
| 22 | | 螺栓 | Screw | 4 | |
| 23 | B205.0-3 | 压缩机底板 | Compressor Base | 1 | 4.2 |

| | | | | | |
|----|----------|-------|--------------------|---|------|
| 24 | B101.7 | 干燥器 | Drier | 1 | 0.4 |
| 25 | | 电源线 | Power Supply Cord | 1 | 2.69 |
| 26 | | 压缩机胶脚 | Grommet | 2 | 50.8 |
| 27 | | 压缩机部件 | Compressor | 1 | |
| 28 | | 螺钉 | Screw | 2 | |
| 29 | | 过载 | Overload Protecior | 1 | |
| 30 | | PTC | PTC Starter | 4 | |
| 31 | | 线盒 | Relay Cover | 1 | |
| 32 | | 线卡 | Relay Band | 4 | |
| 33 | B209.0-1 | 百叶窗 | Shutter | 1 | 1.1 |